

Scaled and easy to read patterns and instructions for a Railway Station made from wood. Compatible with Garden Scale Railroads and Garden Town Houses or Buildings

- Build station from 1/4" plywood
- Purchase doors and windows or
- Build doors and windows from 1/8" Balsa wood or Hardwood and plastic glazing for panes. Garden Towns Doors and Windows patters sold separately.

- Optional: Purchase and add lights, using manufacturers instructions

Patterns
Railway Station complete with dormer

Overall Dimensions:
Foundation: 36-1/2" x 38"
(including platform)
Building: 18" x 30-1/2"
Walls 9" high with 25"
roof peak

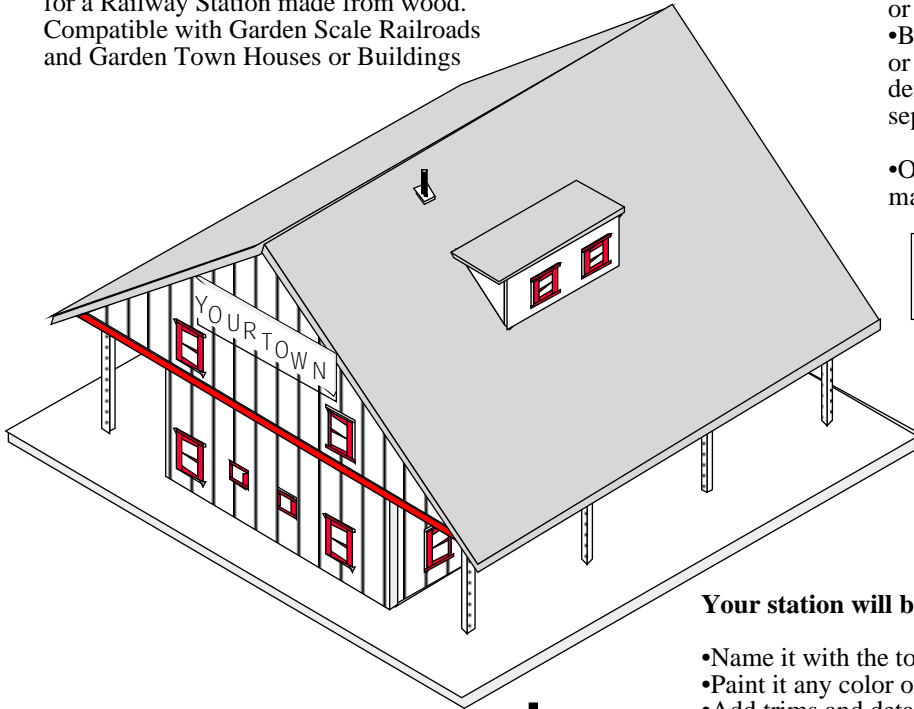

Your station will be unique!

- Name it with the town of your choice
- Paint it any color or colors you wish
- Add trims and details at will (we've included a few ideas)
Use your imagination!

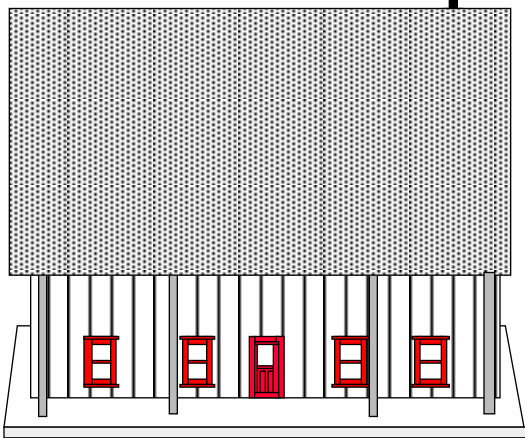

Front

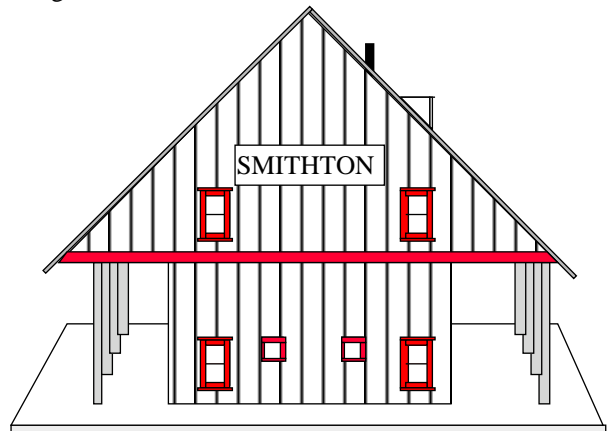

Side

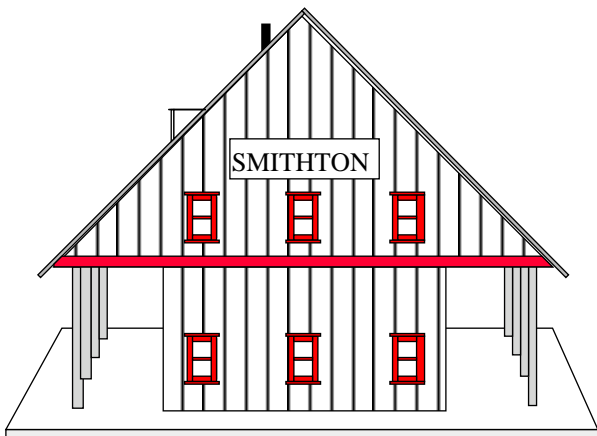

Side

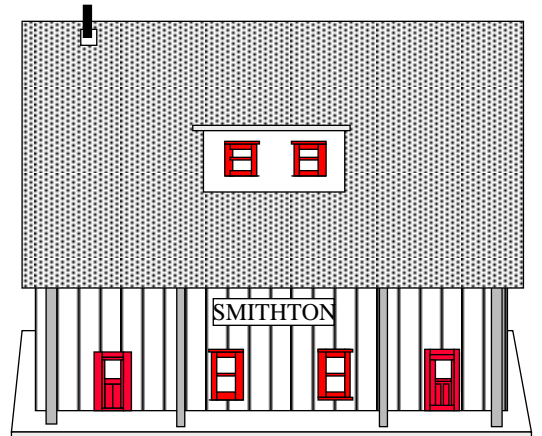

Back
Track side

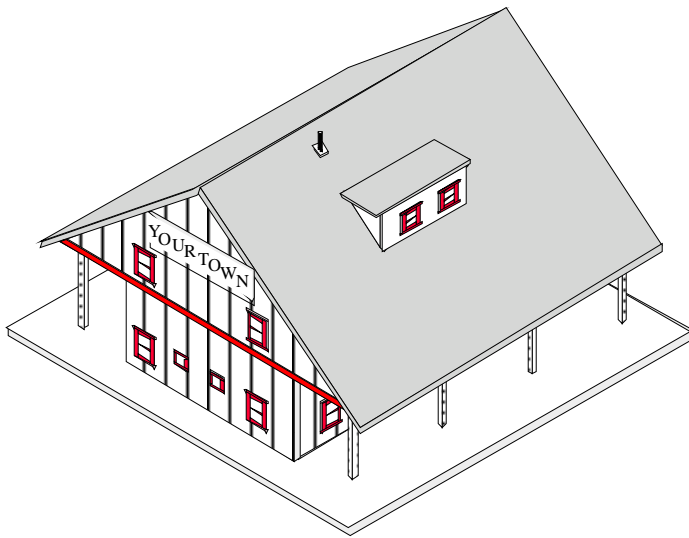

Introduction

Thank you for purchasing our Garden Towns Railway Station pattern. It was designed to accompany the Garden Town Houses and the Garden Town Buildings series. All were instigated by a happy retired "dad" who loves trains of any size and most recently the Garden Scale Trains. However, the scaled buildings can be used to add interest to your flower gardens, fish pond or whatever ideas you may have. They can be used as a backdrop toy for a child. They are as unique as you wish to make them and inspire a nostalgia for a few years gone by.

Enjoy your project!

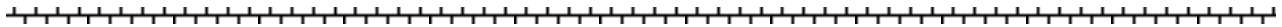

Before You Begin

Tools and Supplies

General	3
Door and Window Requirements	4
Signs and Trim	
Working With Small Items	5
Layouts -	6
Building and Frame	

Hints and Tips

Two Ways to Assemble Roof	7
---------------------------	---

Patterns for Building

Frame, signs and trim	8
Building	9
Rooftop pipe	10

Dormer

Patterns	11
Assembly	12

Walls

Door and windows placements	13
-----------------------------	----

Assembly

Walls	15
Building	17

A note about the Doors and Windows

Opening Type Doors - If you use commercially purchased doors, you will have to cut into the house frame. The size of the opening will depend upon the doors and windows you purchase and the instructions which come with them.

Non-Opening Doors-Such as Kiva Design Garden Town Doors and Windows, which you build yourself, you can build a simple "box frame" for the house. The window openings will be above the frame and the 1/8" thick doors will fit into the 1/4" walls.

Framing

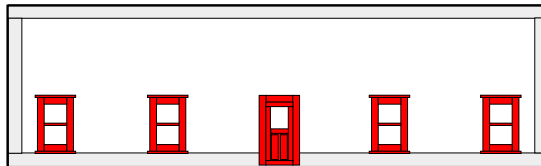

Non-opening door can be installed without cutting into the frame

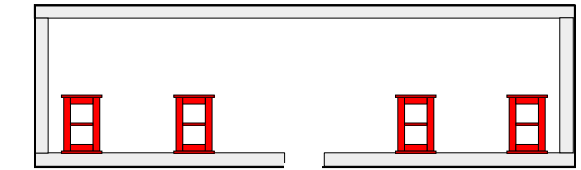

Opening door: Cut appropriate width for door from frame.

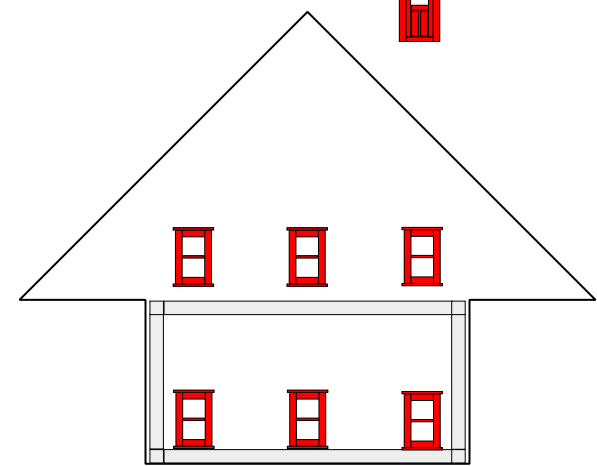

Guide for
1" x 1" x 8'
Furring Strips

1	8'	96"
2	16'	192"
3	24'	288"
4	32'	384"
5	40'	480"

- Buildings are constructed from 1/4" thick plywood
- Framing for the walls is made from 1" Furring strips (nominally 3/4" thick)
- Garden Town Doors and Windows are made from 1/8" thick Balsa wood or Hardwood and plastic glazing for the window panes
- Windows and doors have to be at least 1" from sides and top (to clear inside building frame)
- Doors are placed at floorline
- Floorline on 2nd floor will be 9" from bottom of wall
- For a few hints to experiment with on the wall finishes, see " Simulated Patterns" in our free **Food For Thought** brochure.



Tools Needed for Building

- Saw (for cutting small wood pieces, a jig saw or coping saw)
- Hammer or Stapler or Air Gun
- Optional Drill for pilot holes
- Clamps
- T-Square
- Level
- Ruler and Pencil (We prefer see-thru rulers with grids for the small pieces)

Supplies Needed - General

- 5/8" Staples or Brads
- 3/8" to 1/2" Small Flat Head wood screws
- 2" Finishing Nails
- Wood Glue
- Paint or Stain -We suggest the water based Acrylic Paints found in a multitude of colors in arts and crafts stores.
- Sealer -Water Base Varnish found with the acrylic paints or a sealer such as polyurethane.
- Optional: Caulking for sealing porches, roofs, etc.

Optional - Items to consider from the hobby store:

Lights - Add Lights according to manufacturers instructions.

You can buy scaled wood shingles for your roof, as well as assorted other detailed items.

Make your own signs with help from a stencil or the stick-on letters and numbers available.

Plus If you are making Doors & Windows from Balsa wood

- X-ACTO knife and metal ruler for guide
- Optional:**
- Ruler - the plastic see-thru kind with 1/8" grid is a plus
- Balsa stripper - This little gizmo is used for making various widths of uniform strips from balsa wood. You can set it to cut small widths, (1/8", 1/4", 1/2" etc.)It saves a lot of time if you prefer to cut your own strips. Of course you can buy the strips "ready made" at a higher price.
- Clamps (small) - For example, the X-ACTO clamps for small pieces are very handy.

Specific Building Supplies		For Details See Page
1/4" Plywood (No. of Sheets)	48" x 141" (1) 4' x 8' and (1) 4' x 4'	6
1" x 1" Furring Strips (nominally 3/4"x3/4") Total	214"	6
Purchased Doors & Windows or 1/8" Balsa or Hardwood (4" x 36" Boards)		4
Doors & Windows	4**	4
Signs & Trims	1**	4
**If you prefer to buy ready made strips for the doors, windows and trims, see page 4		
Clear Plastic Glazing for Windows 8" x 10" Sheet	1	4
Wood Dowel - 3/8" Dia		
Rooftop Pipe	2"	22
Porch Posts (optional)	72"	10
Optional Small Parts Frame - Page 5		
1/4" Plywood - 12-3/4" x 12-3/4"		
1" x 1" Furring Strips - Add 52"		

Doors and Windows

Option: You can purchase ready-made doors and windows which actually open. For example, Grandt Line carries a well made and ready to paint plastic selection for Scale 1:24.
or
you can make your own (Garden Towns Doors and Windows Patterns by Kiva Design) These doors and windows are also 1/24 scale, but are a little larger overall for ease in building. They are non-opening (no hinges).

The following are samples represented for the scaled dimensions.
Buildings are illustrated with the Kiva Design Samples. Neither of the samples are inclusive all all doors and windows available.

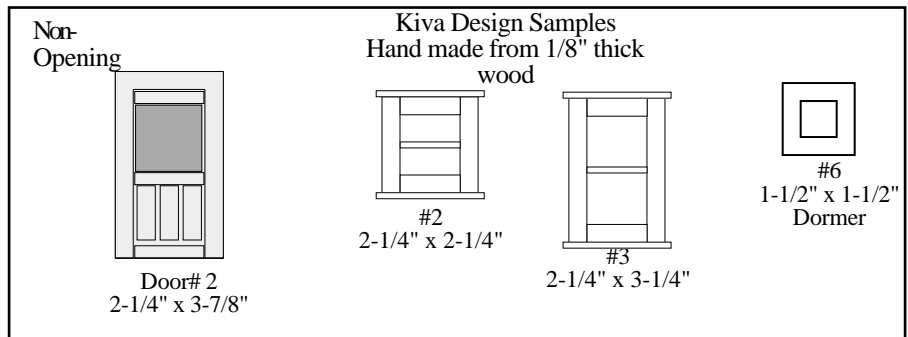
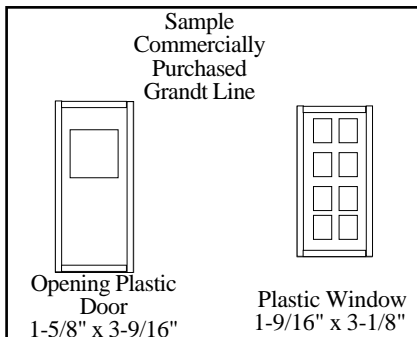

•Purchased Doors and Windows as required OR

•1/8" Balsa wood or Hardwood for Doors and Windows:
4" x 36"
(common size at hobby shops)
See detail below

Number of Doors and Windows required for Railway Station			
Doors	Kiva Design # 2 Windows	Kiva Design # 3 Windows	Kiva Design # 6 Windows
3	2	16	2

•Clear Plastic for Windows
8" x 10" Sheet
(from hobby shop framing area)

•1/8" thick Balsa Wood or Hardwood
Need 4 (4" x 36") boards for making doors and windows for Railway Station*

Or

Alternately, if you prefer to use ready made strips, you will need the following:

Purchase 1/8" thick Balsawood or Hardwood

Amount Needed for Doors & Windows

Boards:
(2) 4" x 36"

Strips:
(1) 1/8" x 24"
(9) 1/4" x 36"
(3) 3/8" x 36"

*Doors and windows shown for the building can be made from the number of boards indicated. However, "we" personally always buy one extra board in the unlikely event that we'll need it to redo our "errors". Left-overs are saved for the next project.

Signs and Trims

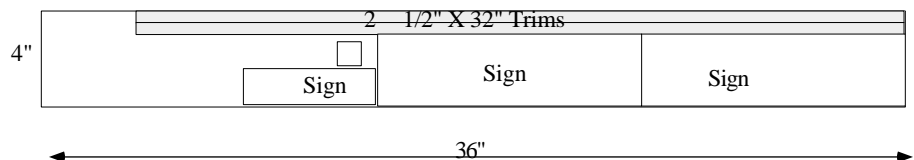

3/8" Diameter Dowel
72" for Porch Posts
2" for Rooftop Pipe

1/8" thick Balsa Wood or Hardwood
Need 1 (4" x 36") board for signs and trim

Optional: Also purchase (2) 1/8" x 1/2" x 36" strips for the trims if you prefer.

Assembly Frame for Small Items

Cut from plywood -1/4" thick or any scrap

Patterns

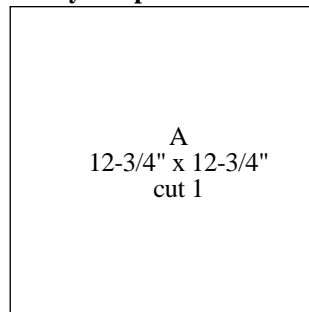

Cut from 1" x 1" Framing (nominally 3/4" x 3/4")

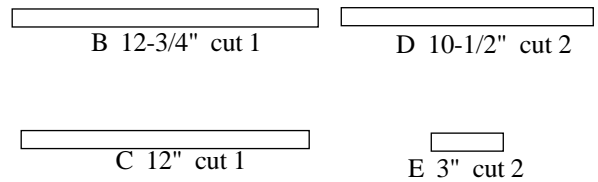

Assembly

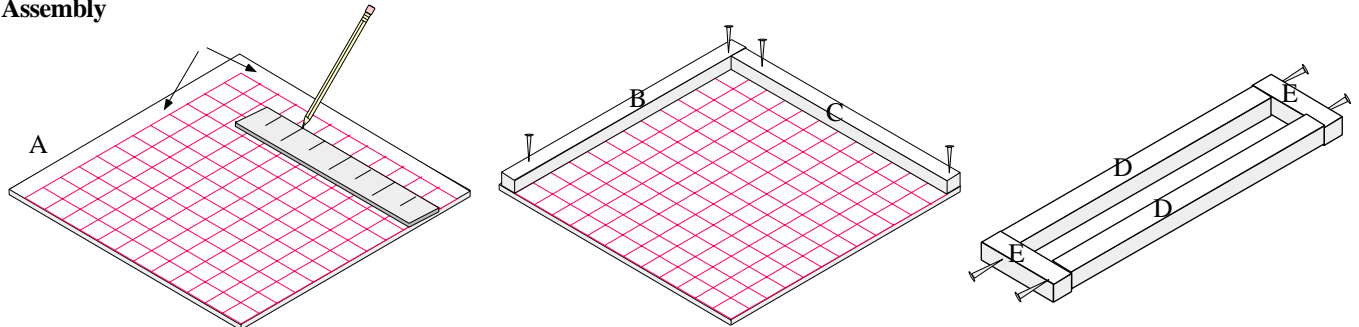

1. Using pencil or pen and ruler, draw lines 3/4" inside of 2 adjacent sides of the base. The frame will be placed in this area. From those 2 lines, draw lines at 1" intervals, forming a 1" grid.

2. Nail and glue frame parts B and C in place, as shown, maintaining a square corner.

3. Using glue and nails, assemble the frame "push bar", as shown. Again, make sure that the corners are square.

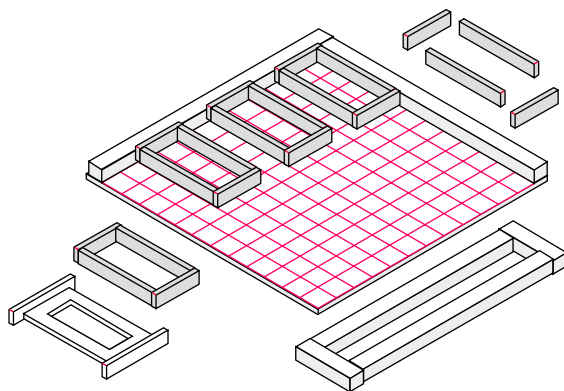

4. Glue parts and assemble inside the frame. The grid will help you keep the pieces straight. You can assemble several "like" pieces at one time.

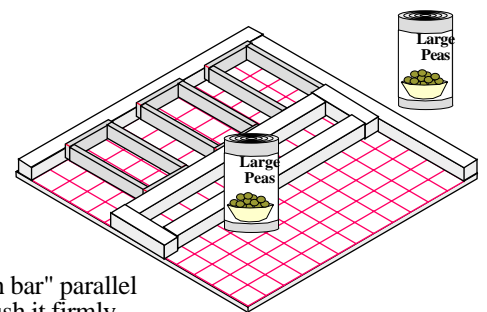

5. Keep the "push bar" parallel to side C and push it firmly against the assembled parts. Use anything with weight to hold the push bar in place until parts are dry. Canned goods you didn't want for dinner work well.

Trimming 1/8" Balsa wood or hardwood

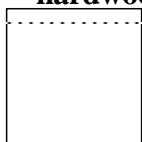

1. Using ruler and pencil make a line 1/8" from the inside edge to be mitered

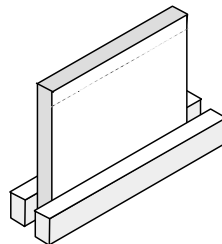

2 Stabilize the piece to be mitered with a clamp or other means

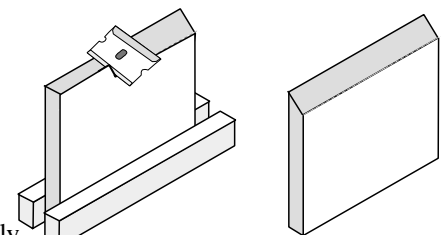

3. With blade, carefully trim from the top outside to the marked line. Alternately, the piece can be planed or sanded.

Trimmed on the inside

Railway Station including Dormer

Layout
Cut from 1/4" Plywood'

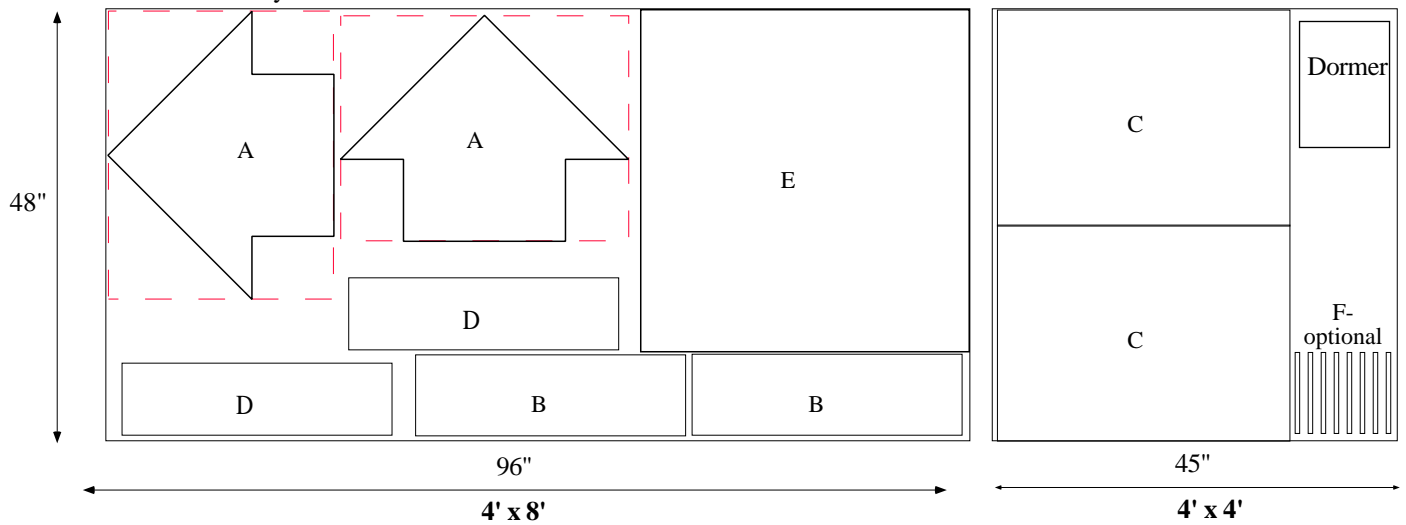

The Frame

You will need to build a frame for which to attach the walls.

See Patterns on Page 8 and Assembly on Page 17

If your building will have doors which do not physically open, you can build a simple box for your wall braces. The windows and doors will fit into the walls.

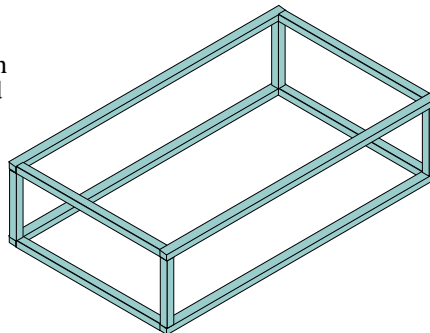

Build this frame if you are using Garden Town Doors and Windows or other non-opening doors

If your building will have doors which do physically open, you will be cutting an opening in the floor frame.

Vertical Braces for the Railway Station are 7-1/2" high.

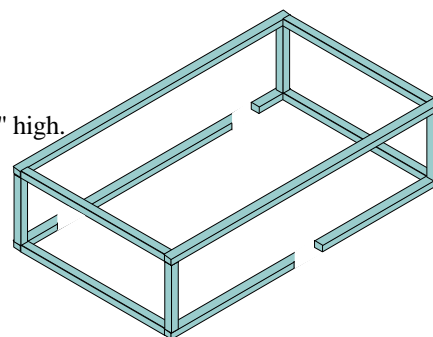

Build this frame if you are using purchased doors which open

Framing
Cut from 1" Furring Strips
(nominally 3/4" square*)

4 @ 30"	120"
4 @ 16"	64"
4 @ 7-1/2"	30"
Total	214"

*Note: If your framing material is a different size than 3/4" square, adjust your first two lengths to fit the diagram for Frame Placement shown on page 10.

Conversion	
Inches =	Feet
12"	1'
24"	2'
36"	3'
48"	4'
60"	5'
72"	6'
84"	7'
96"	8'
108"	9'
120"	10'
132"	11'
144"	12'
156"	13'
168"	14'
180"	15'
192"	16'
204"	17'
216"	18'
228"	19'
240"	20'
252"	21'
264"	22'
276"	23'
288"	24'
300"	25'

Roofs made from 1/4" plywood

M Areas that need to be mitered in order to fit will be designated with this icon on the pattern. The specific mitering angle is noted on the pattern page.

There are two ways to assemble your 45° roof. Either way will allow the two halves to meet at the top smoothly.

Method 1 - Miter the Tops

The first and more professional procedure is to miter the top edges of the roof halves on the inside. One way you can do this is to cut out the roof with a jigsaw which has an adjusting base plate. Example:

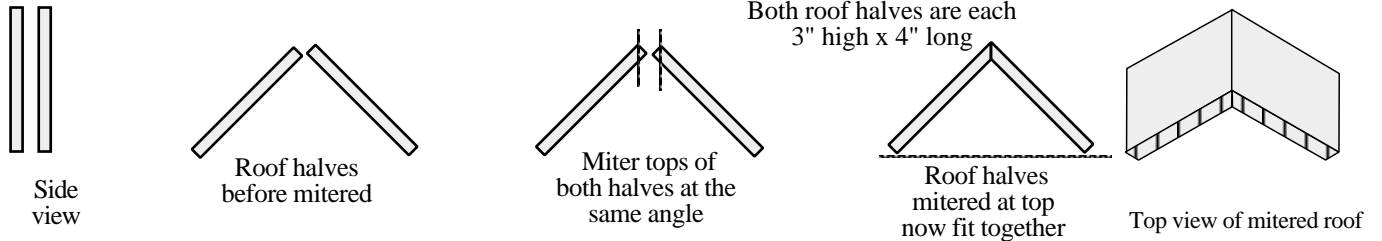

Optional:

As a matter of taste, you may also choose to miter the inside bottom edge of the roof. If you miter the bottom of the house roof, you should also miter all addition roofs you will use with the house.

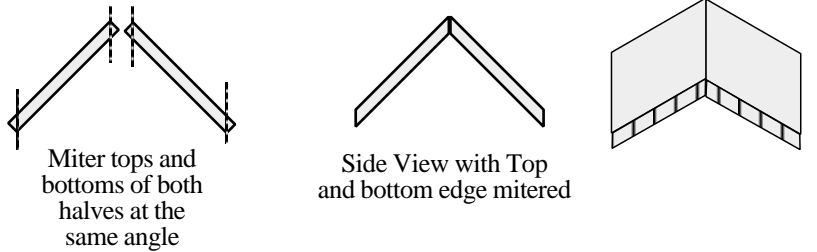

Side wall Option

Mitering the side wall will allow the roof to fit better.

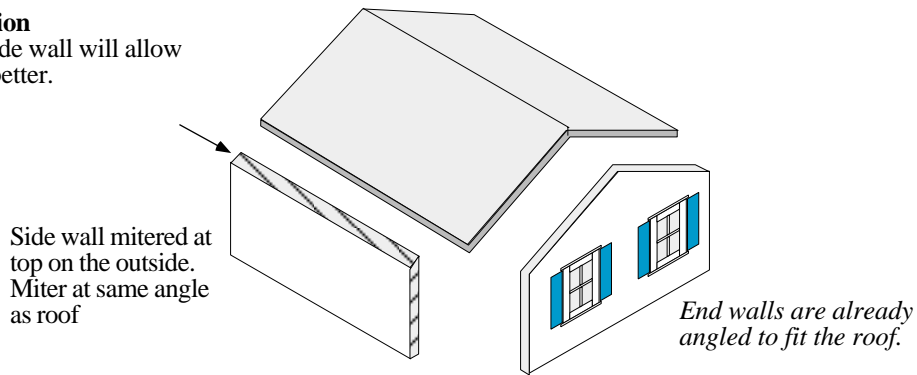

Method 2 - No Mitering

Add 1/4" to the height of one roof half only
Example

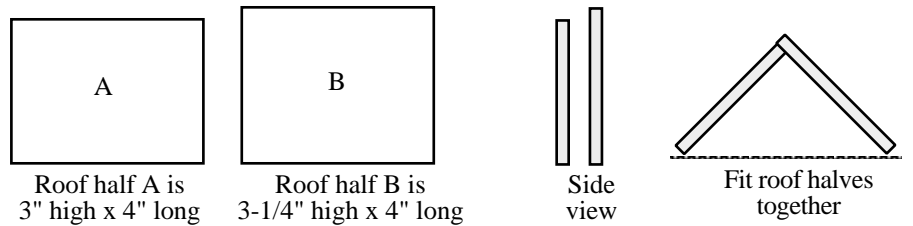

Roofs made from 1/2" plywood

Add 1/2" to the height of one roof half only

No matter what depth of wood you use, Always add the depth of the wood to one half only

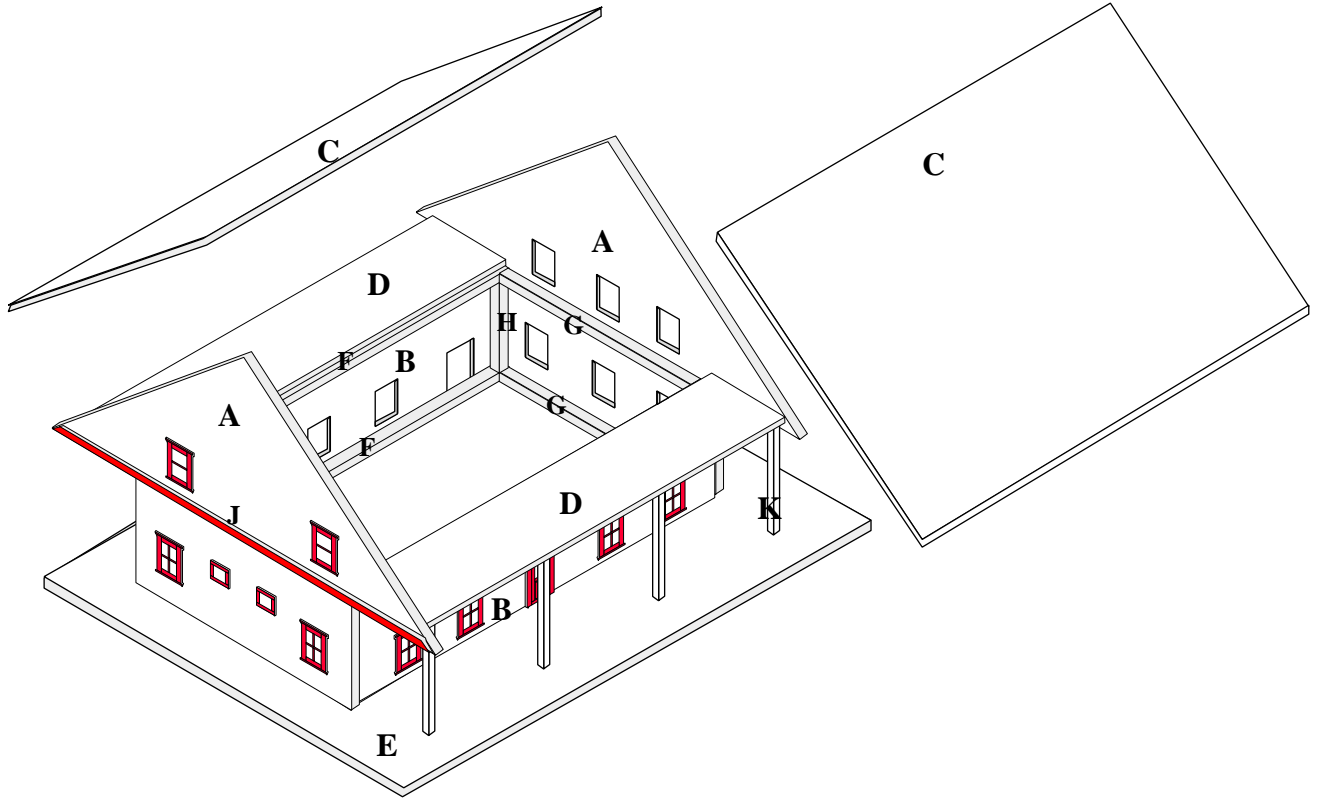

Cut from 1/8" thick Hardwood

Signs
Suggestion: Allow 1" per letter and space for End Signs. Allow 1/2" for Back Sign.

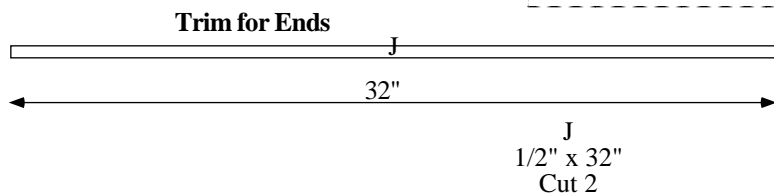
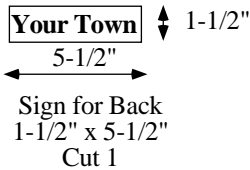
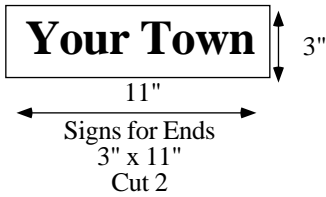

Patterns - The Frame
Cut from 1" Furring Strips
(which are nominally 3/4" x 3/4" square)

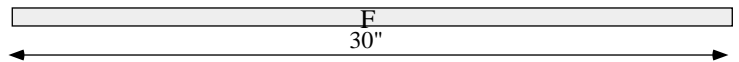

F
Front and Back
30" Long
Cut 4

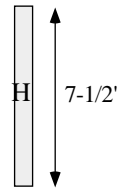

H
Vertical Braces
Cut 4

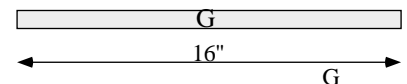

G
Ends
16" Long
Cut 4

**Patterns -
the Building
Cut from
1/4" Plywood**

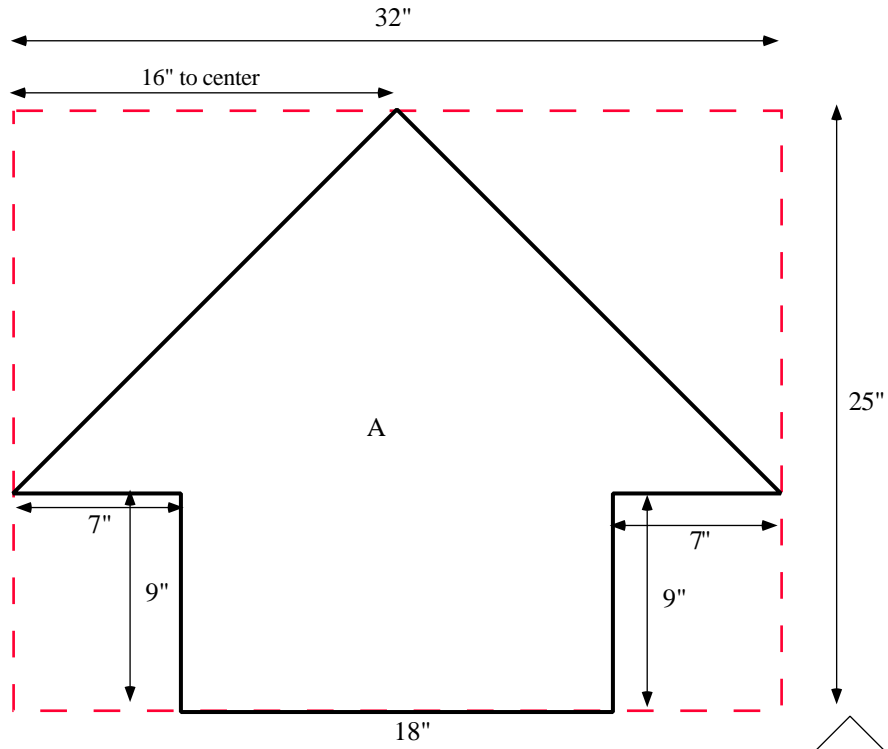

A
End Walls
Begin with rectangle 25" x 32"
Measure and cutout as shown
Cut 2

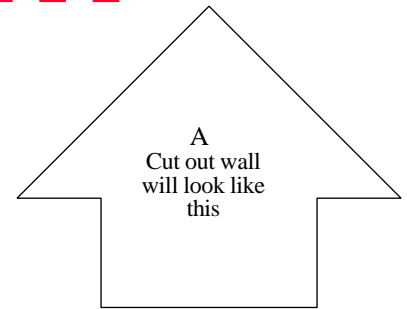

A
Cut out wall
will look like
this

M Miter @
45°

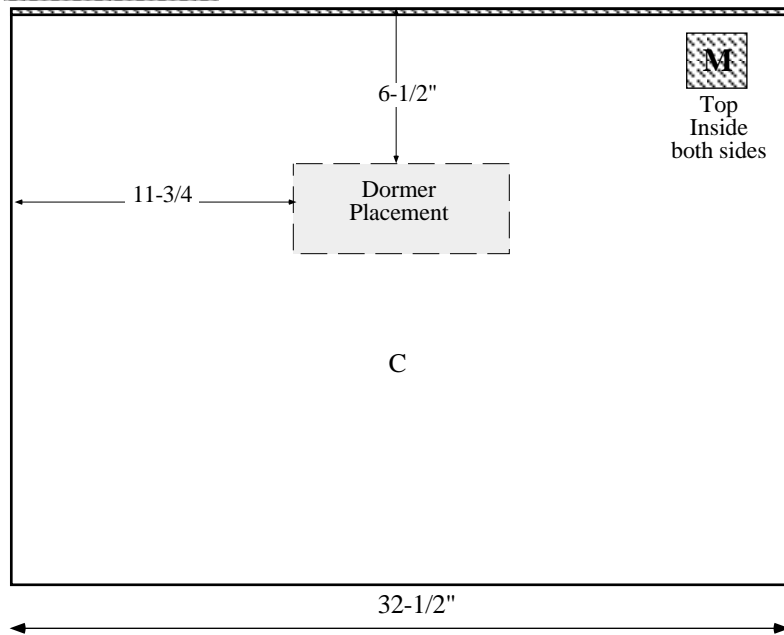

C
Roof Half
24" x 32-1/2"
Cut 2

Dormer placement is
shown for reference

***See Before You Begin - Hints and Tips
Two Ways to Assemble 45° Roofs
For non-mitered roof, add 1/4" to height for one roof half only

**Patterns -
the Building
Cut from
1/4" Plywood**

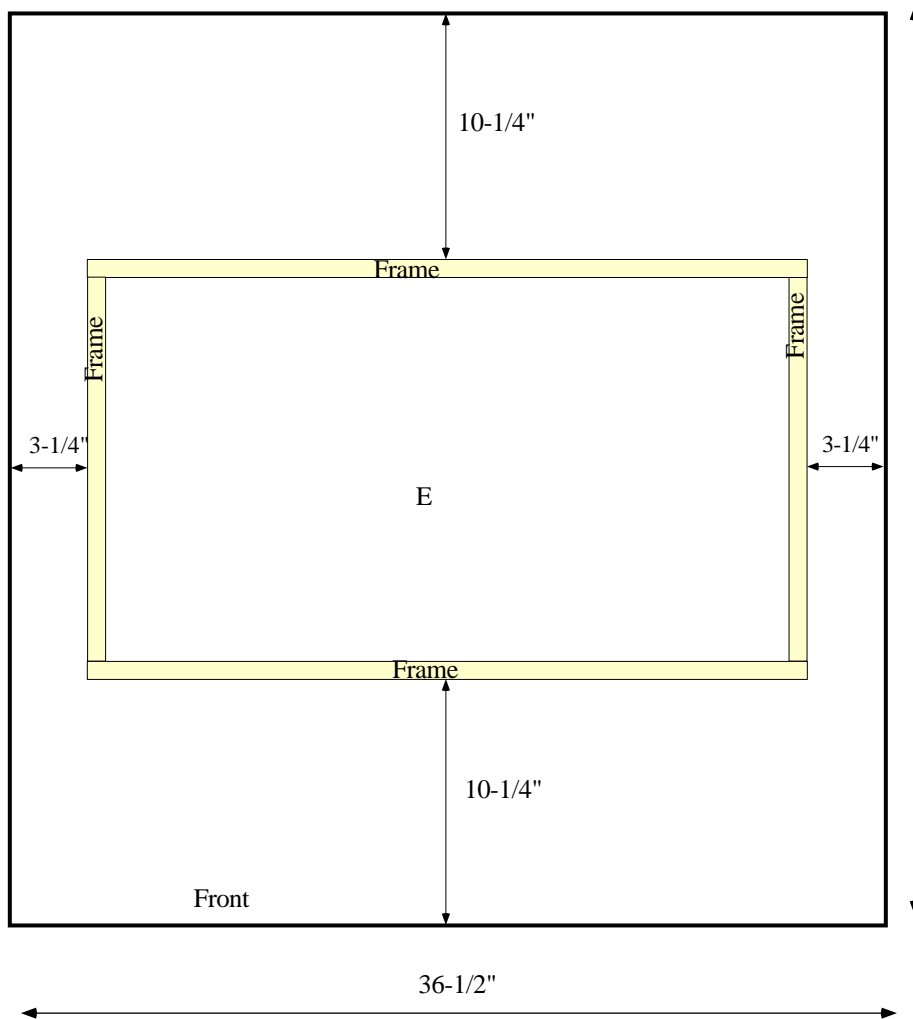
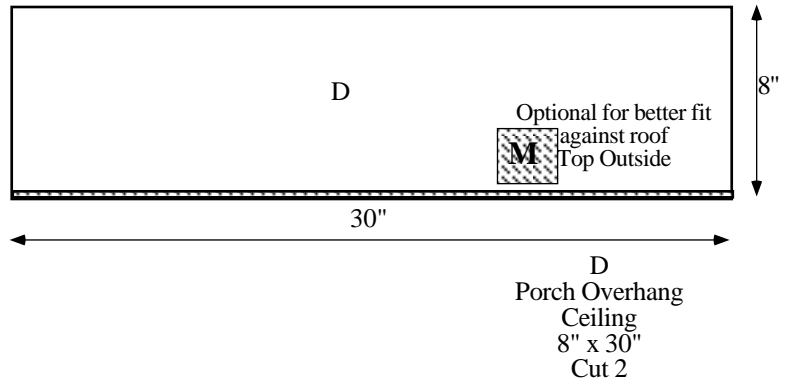
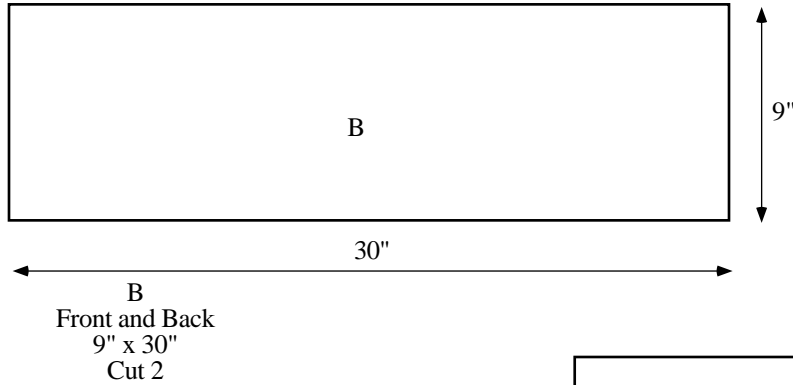

E
Foundation
36-1/2" x 38"
Cut 1
*Frame placement
is marked on the
foundation.*



38"
"K"
Porch Posts
1/2" X 9"
Cut 8
**Option: You can use
3/8" Dowel if preferred.
You'll need 72"**

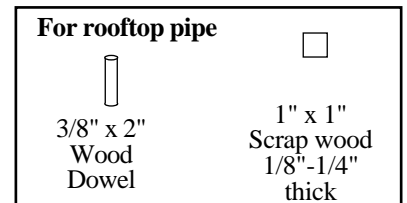

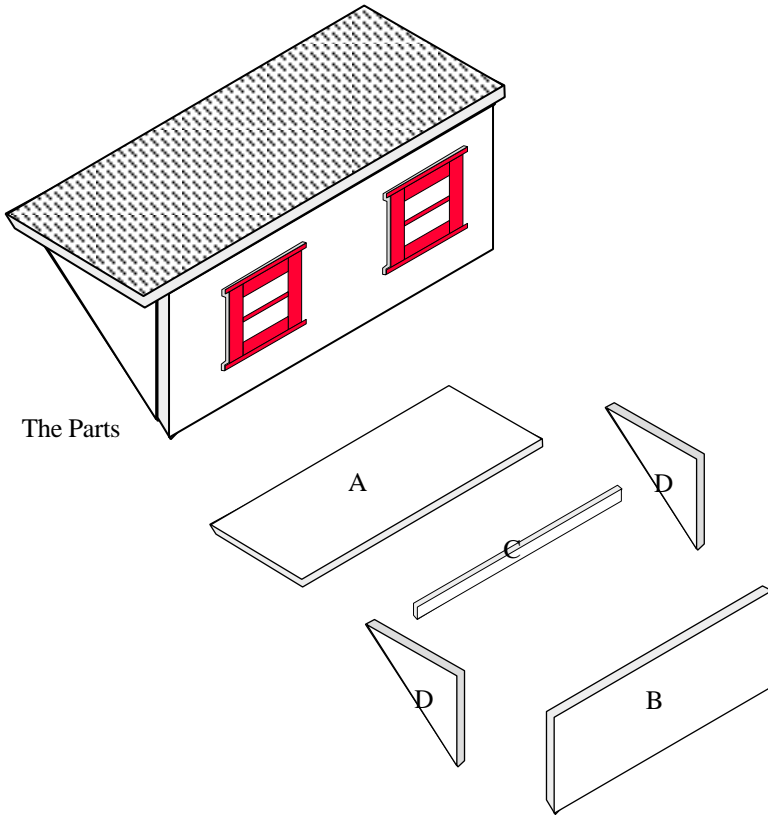

Layout for Railway Station Dormer

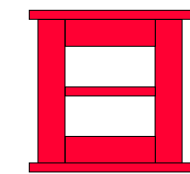
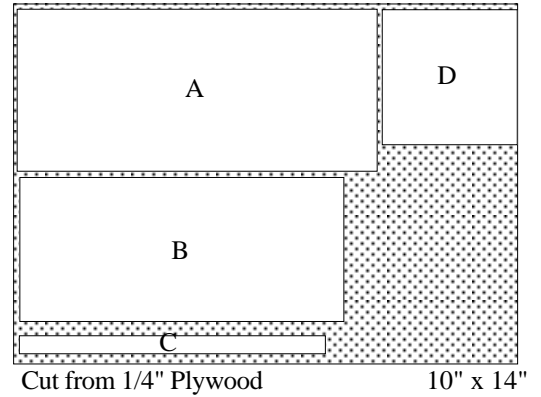

Patterns
Cut from 1/4" Plywood
Miter as indicated

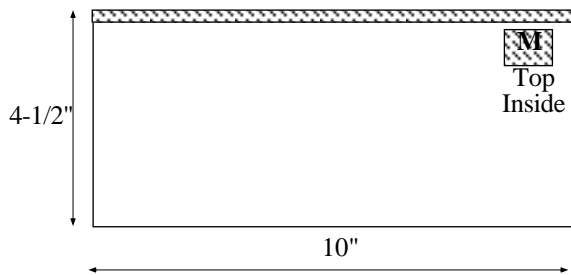

A
Roof
4-1/2" x 10"
Cut 1

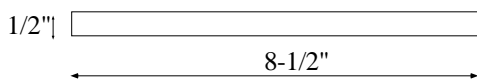

C
Inside Brace
1/2" x 8-1/2"
Cut 1

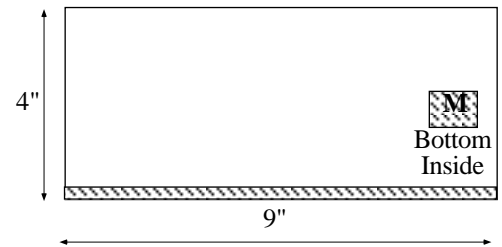

B
Front
4" x 9"
Cut 1

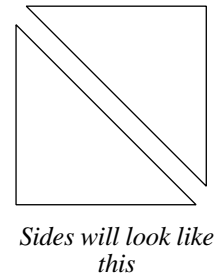
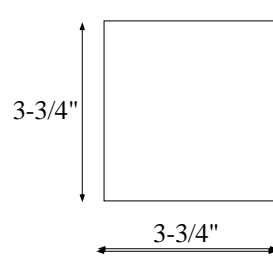

D
Sides
3-3/4" x 3-3/4"
Cut one
and then cut
diagonally through
center

Assembly

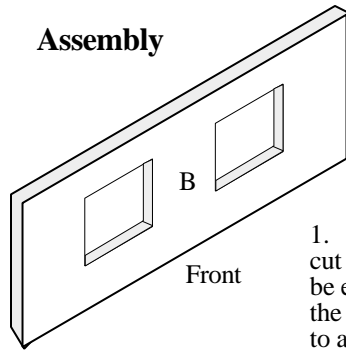

1. Window opening will have to be cut prior to assembly. It will probably be easier if you also go ahead and install the windows, as they should be in place prior to adding the roof.

Note inside bottom of front is mitered to fit the roof

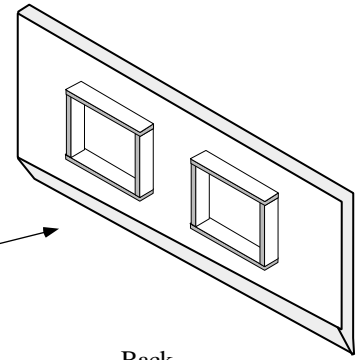

2. The front is assembled in front of the two sides. Glue and nail front to sides, keeping a 45° angle for the roof. Place the brace inside the two sides to help keep an even spacing. Brace should be a bit above the bottom of the sides, so that it won't interfere with the angle. Glue and nail in place.

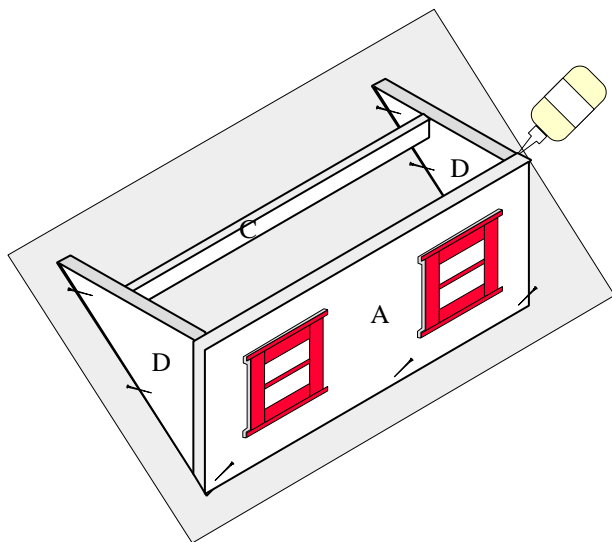
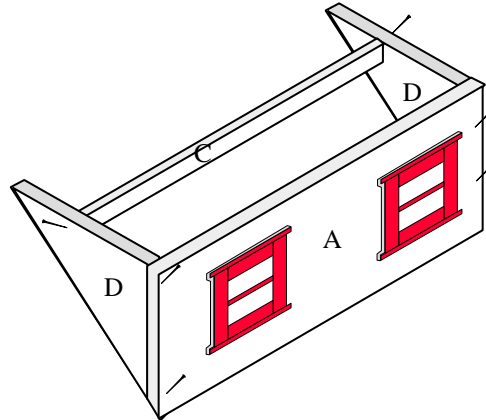

3. Attach the dormer to the roof of the house, again using a light bead of glue and nails or staples. Run a bead of glue along the top exposed wood of the dormer, where the roof will fit.

Note inside top of dormer roof is mitered to fit the main roof

4. Run a bead of Wood Glue along the top inside mitered sides of the dormer roof

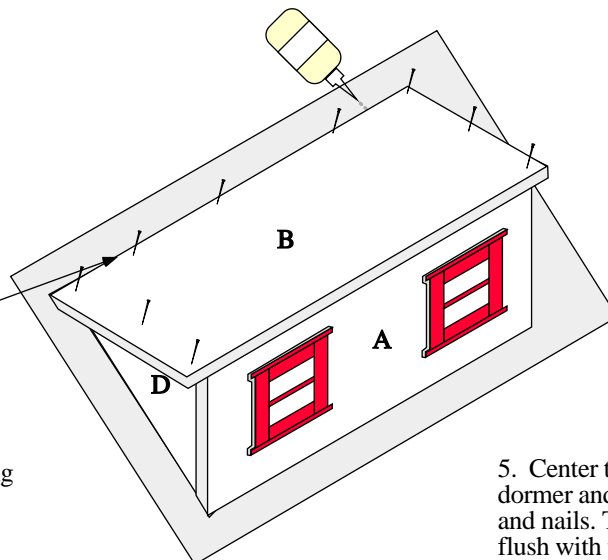

5. Center the dormer roof on to the dormer and securely attach with glue and nails. The back of the roof will fit flush with the roof. There will be a 1/2" overhang of the roof on front and sides.

End Wall

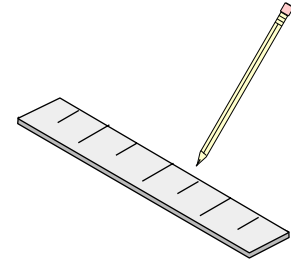
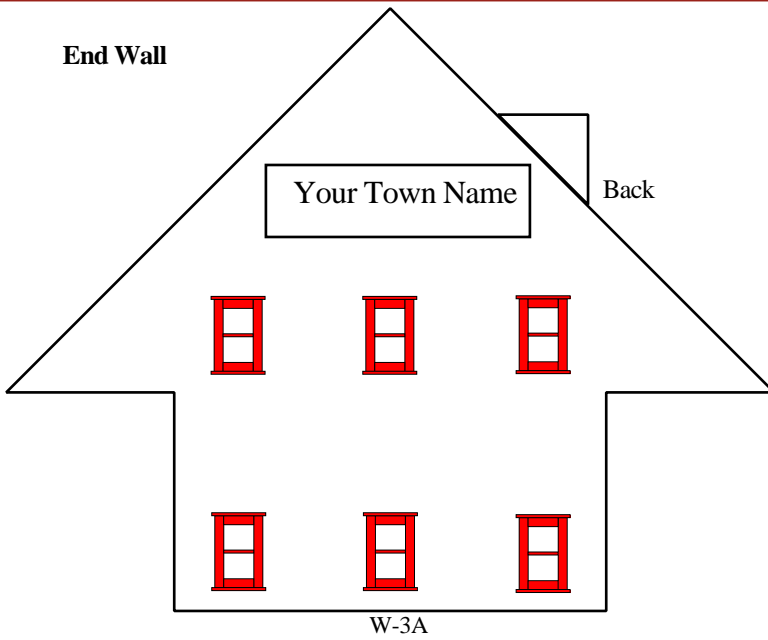

Using Ruler and pencil, draw lines on your end wall:

Vertical lines

1-1/2" from each side for Template W-3A

7-7/8" from each side for Template W-3A

Horizontal lines

9" from bottom

15" from bottom

Place window and door templates on the lines as shown and mark your window cut-outs. Bottom of templates will be on the floor line or on the 9" horizontal line for upper windows.

The 15" horizontal line is guide for sign placement.

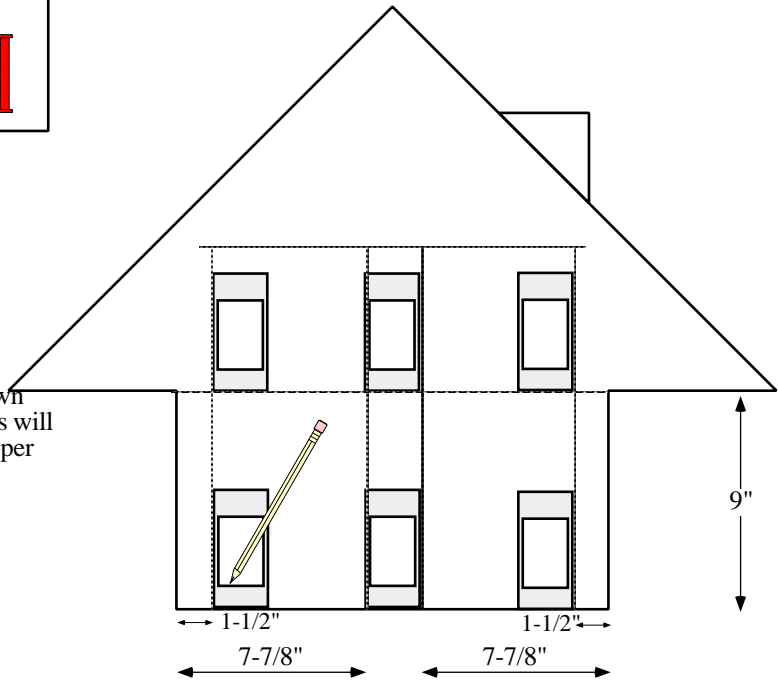

Front Wall

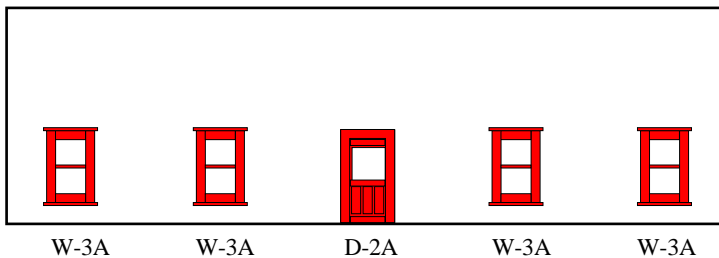

Using Ruler and pencil, draw lines on your end wall:

Vertical lines

1-1/2" from each side for W-3A Template

7-3/4" from each side for W-3A Template

13-7/8" from each side for D-2A Template

Place window and door templates on the lines as shown and mark your window cut-outs.

Bottom of templates will be on the floor line.

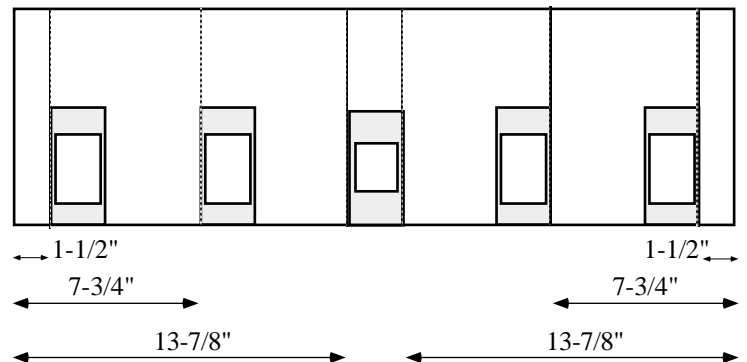

End Wall

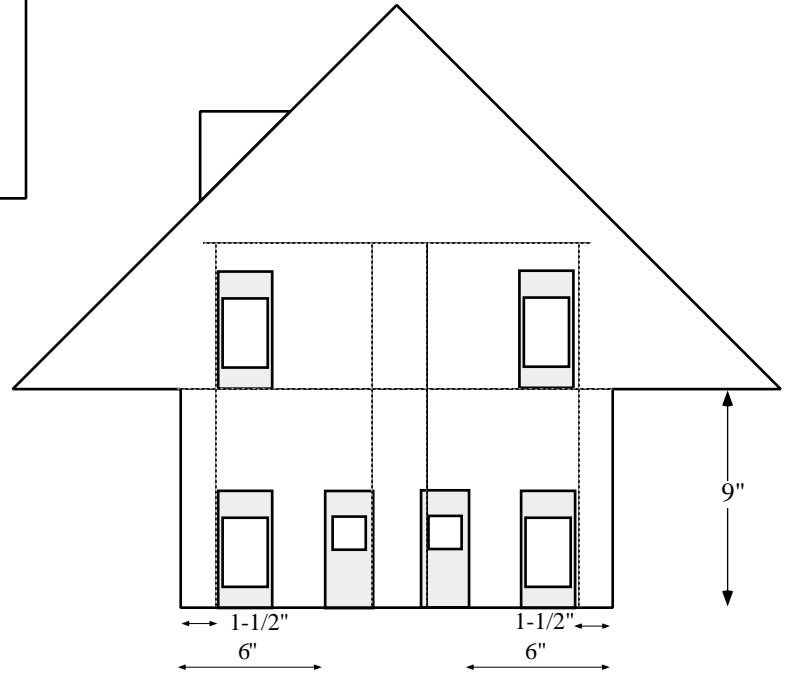
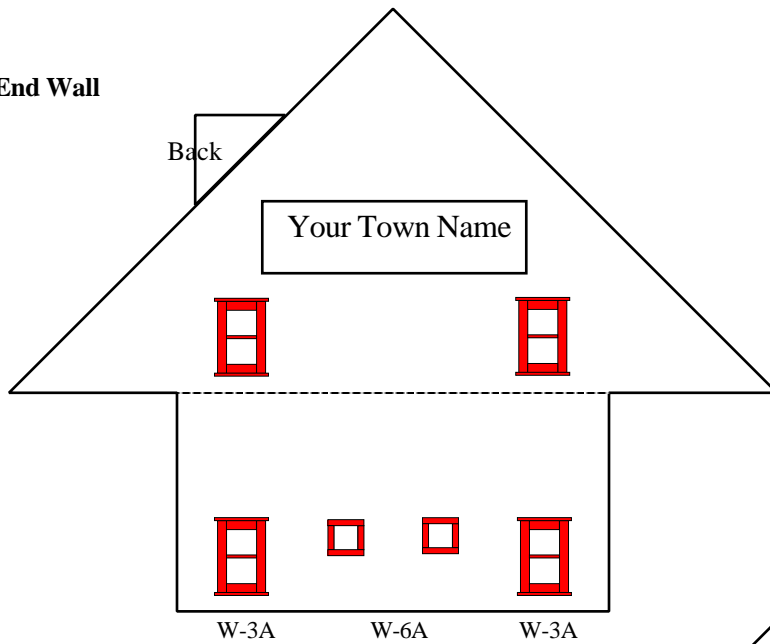

Using Ruler and pencil, draw lines on your end wall:
Vertical lines
 1-1/2" from each side for Template W-3A (top and bottom)
 6" from each side for Template W-6A
Horizontal lines
 9" from bottom
 15" from bottom

Place window and door templates on the lines as shown and mark your window cut-outs. Bottom of templates will be on the floor line or on the 9" horizontal line for upper windows.

The 15" horizontal line is guide for sign placement.

**Back wall
(Track Side)**

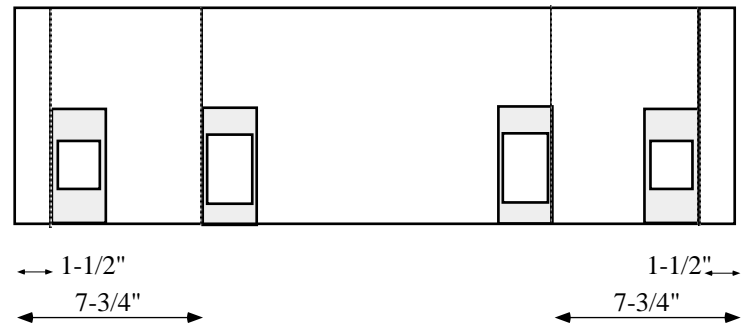
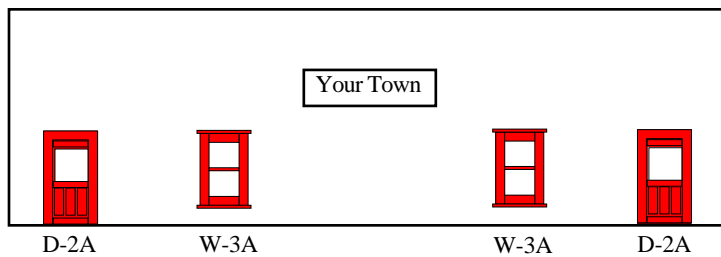

Using Ruler and pencil, draw lines on your end wall:
Vertical lines
 1-1/2" from each side for D-2A Template
 7-3/4" from each side for W-3A Template

Place window and door templates on the lines as shown and mark your window cut-outs. Bottom of templates will be on the floor line.

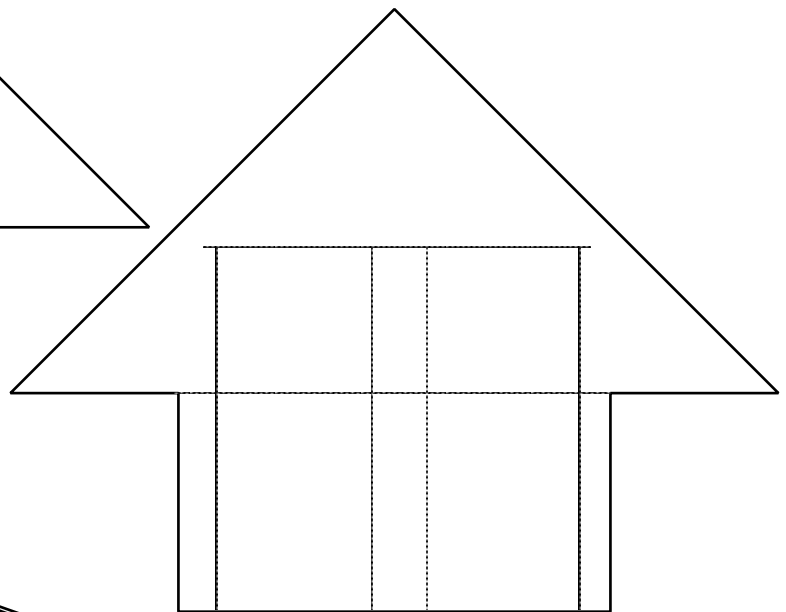
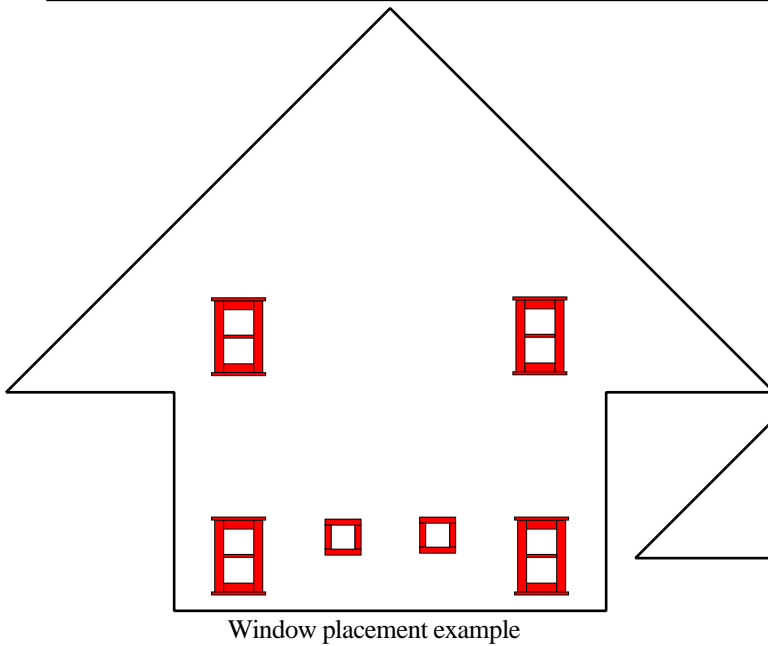
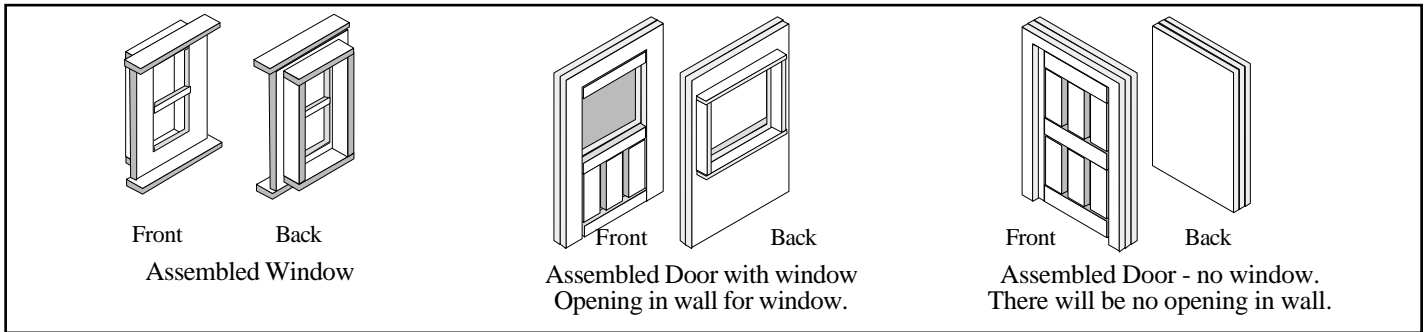

Template for Window Opening in Wall

Important: After you cut your templates, check that the sizes and openings are accurate according to dimensions noted. Use a ruler to check. *You can take a finished window and make sure that it physically fits into the template opening.*

Using your side guide lines, place the template as follows.

Ground floor:

Bottom of template will be on bottom of wall

2nd floor

Top of template will be on the 9" horizontal line

Using template and pencil, mark the window opening on the building. Cut out opening on building.

The opening is now ready for the finished door or window.

Note: Doors and windows should be painted or stained before you actually insert and secure them into the building. Before gluing windows, check to see that they will easily fit the wall openings. Trim openings if necessary.

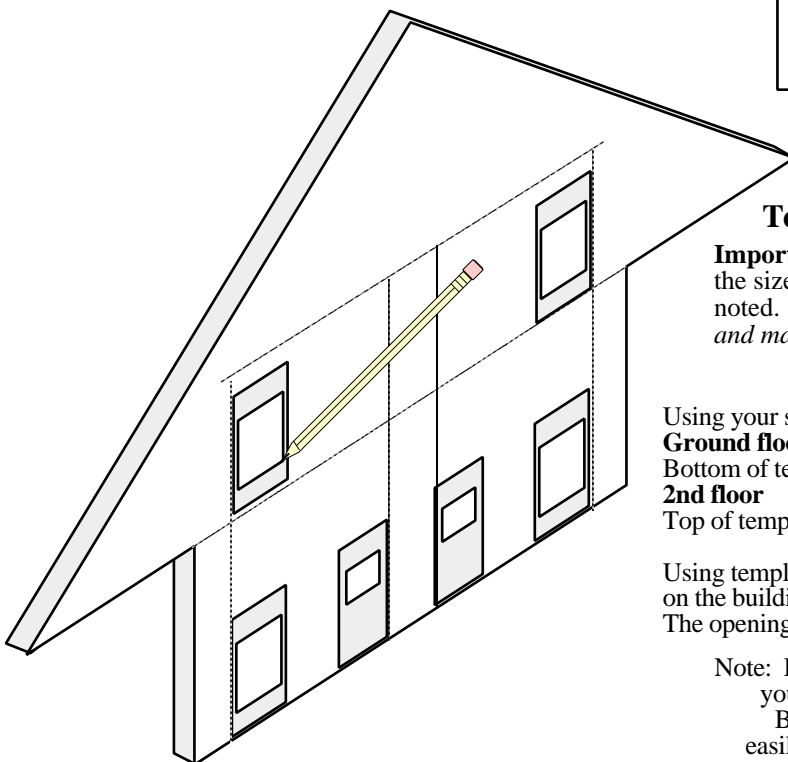

Front View

**Building should be assembled
prior to installing doors and
windows. See page 20**

Place some wood glue on the flat backs of the finished window and door with window. (around the frame) This will adhere to the front of the wall.

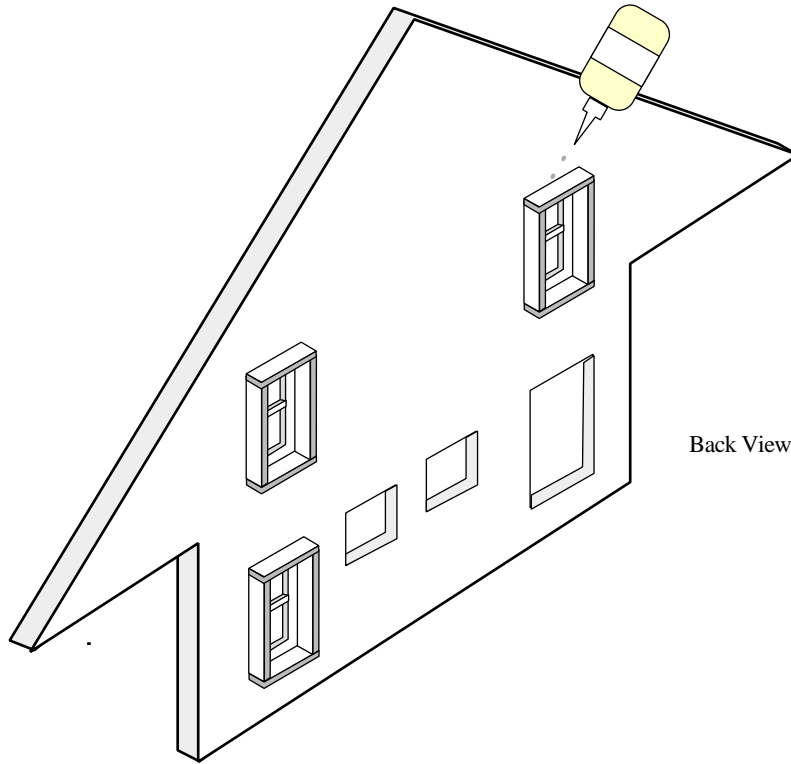
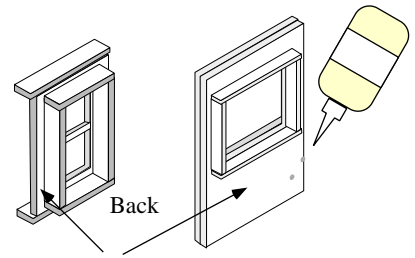

Back View

Insert the glued window or door with window into the appropriate wall opening. Look at the front side and using a level, make sure the window is straight.
Run a bead of wood glue around the window brace. Allow the glue to dry.

Door with no window does not have a wall opening. Lightly nail and glue door in place.

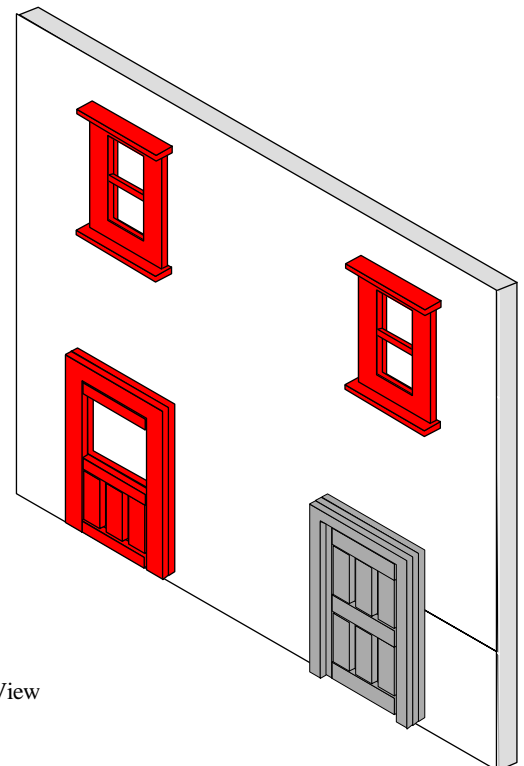

Front View

The following illustrations will show assembly of the Railway Station.

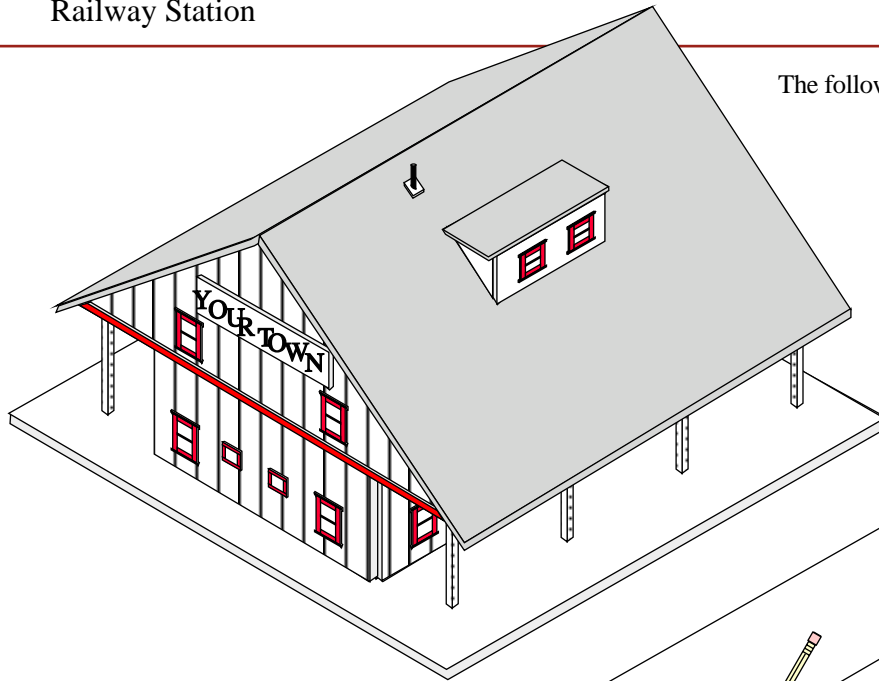

1. Foundation
Lay the cut out foundation on a flat surface. Use the measurements shown on the foundation pattern (page 10) and, with pencil and ruler, draw in guidelines where the frame will be secured. Flip the foundation over and make the same guidelines on the bottom.

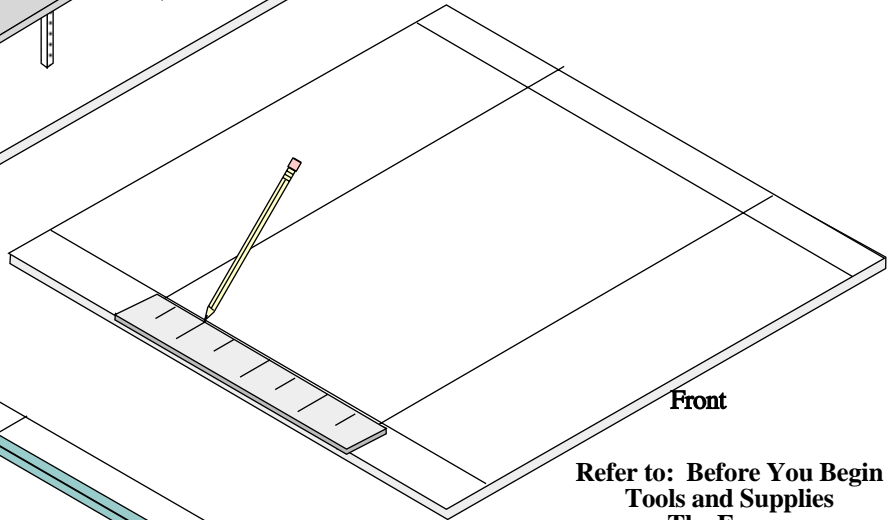

**Refer to: Before You Begin
Tools and Supplies
The Frame**
**Do not cut openings in bottom
frame if using Garden Town
or other non-opening doors.**

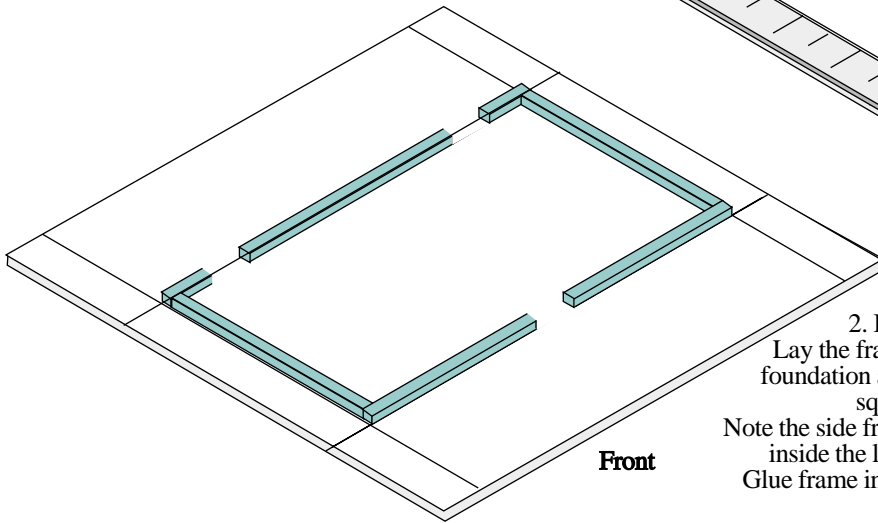

2. Bottom Frame
Lay the frame pieces out on the foundation as shown, maintaining square corners. Note the side frame pieces are assembled inside the longer front and back. Glue frame in place. Immediately go to step 2A

2A. to strengthen the assembly

Before the glue is completely dry, turn the foundation upside down. Drill pilot holes and insert small flat head wood screws (or nail) the frame from the bottom side. The guidelines will help you, as frame is glued inside of the lines. Just put a couple of screws or nails in each section, avoiding any cutouts for doors if applicable.

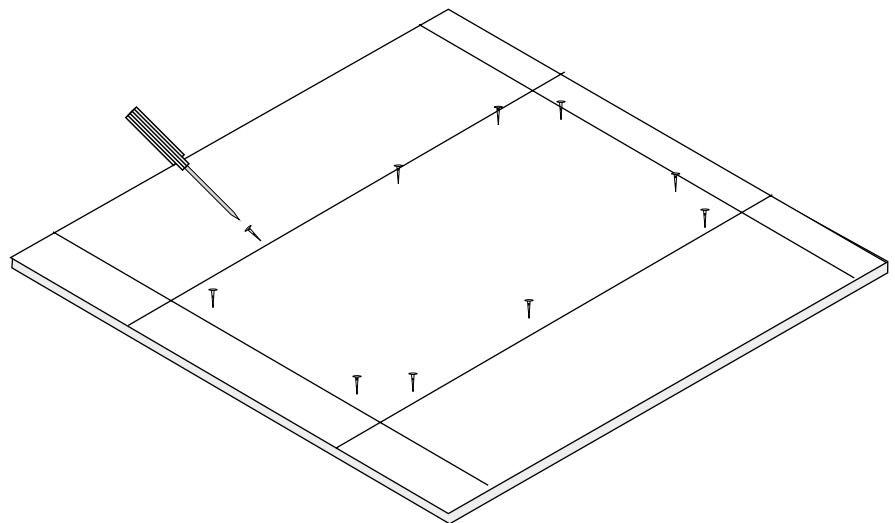

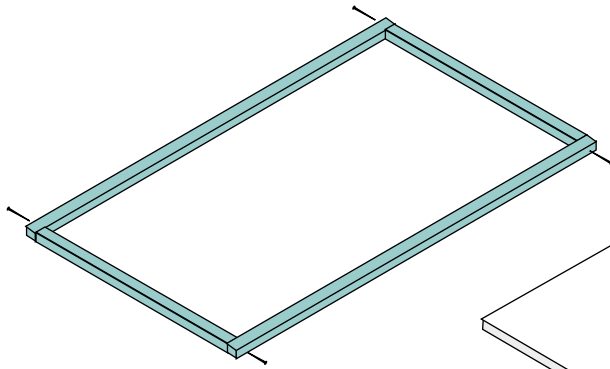

3. Top Frame

The top frame is assembled in the same manner as the bottom, except that there will be no openings for doors.

Lay the pieces out on a flat surface. Glue and nail top framed together, again maintaining corner angles.

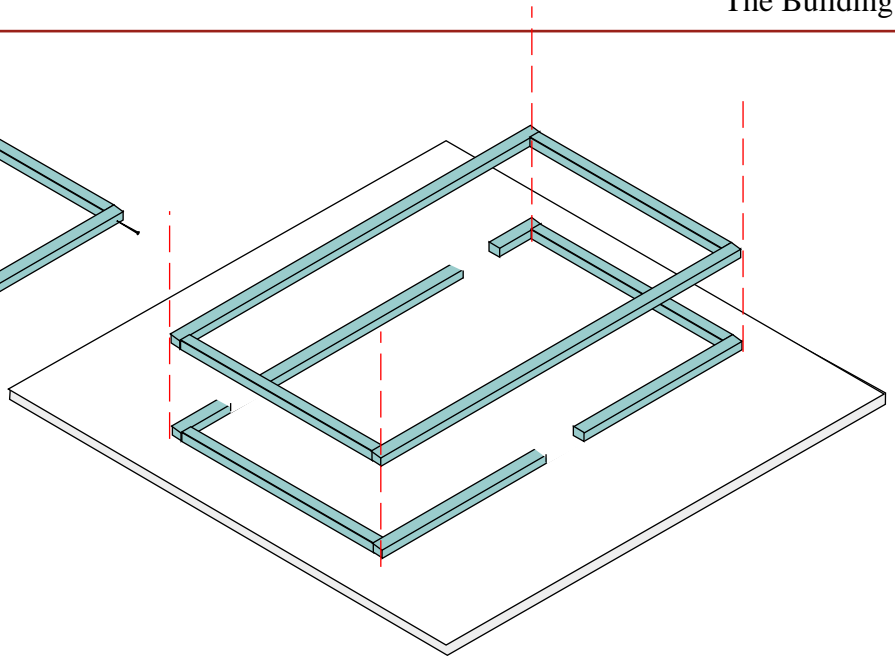

4. Check alignment of the two horizontal frames. Position the top frame directly over the bottom frame to ensure that the pieces are in alignment. The two frames should line up vertically and be the same dimensions in all sides. If they don't, double check your dimensions and make adjustments. Lay the Top aside.

Note: The openings shown in the bottom frame are in case that you are using purchased opening doors. Width of opening depends upon instructions received with your doors. If you are not using opening doors, do not cut openings.

5. Vertical Studs

You will need 1 stud on each corner. Glue and nail the studs in place.

Note: Nailing the studs will be easier if you begin with drilling a small pilot hole for the nail.

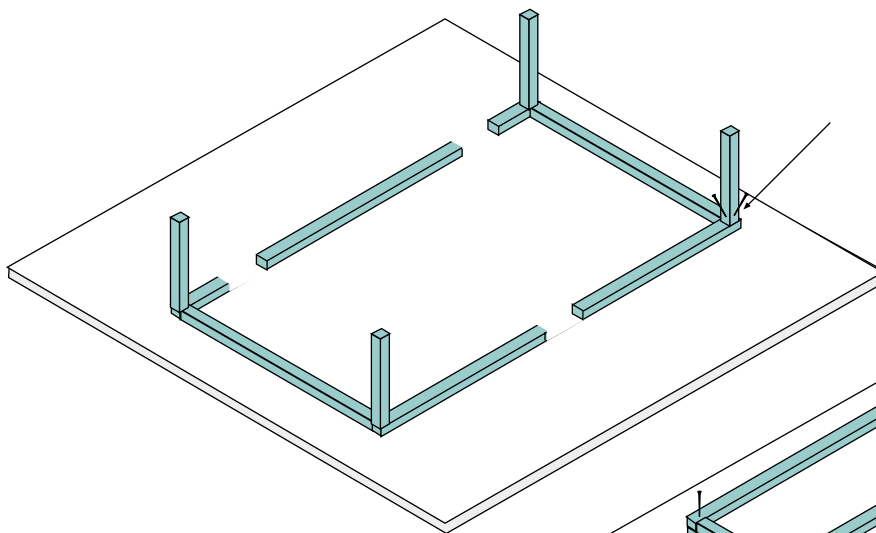

6. Finish assembly of frame. Lightly glue the tops of the vertical studs. Place the assembled top brace on top of the studs, matching up with the bottom brace. Nail or staple the top brace to all vertical studs.

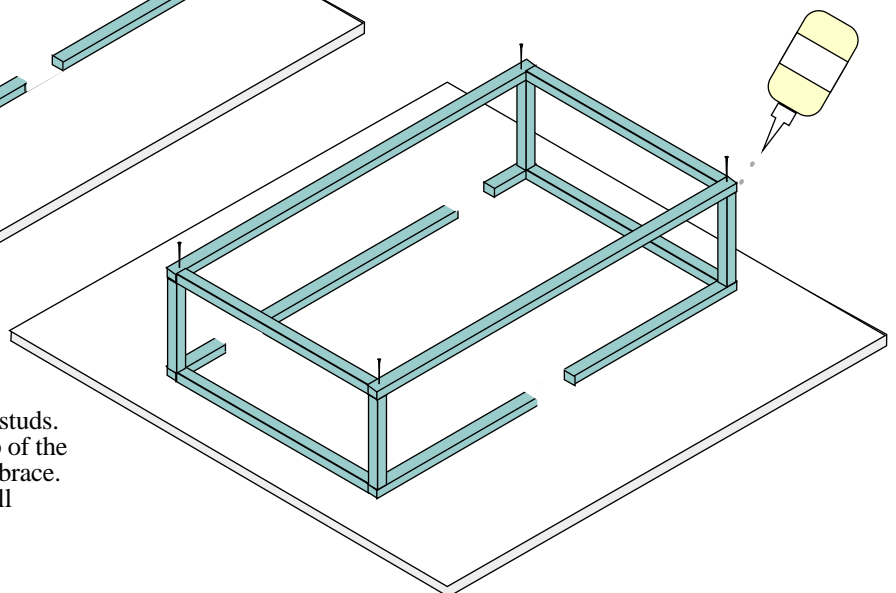

7. The Walls -
Cut out all walls, including openings for
windows and doors.
See **Door and Window Placement** - Walls
for placement of openings

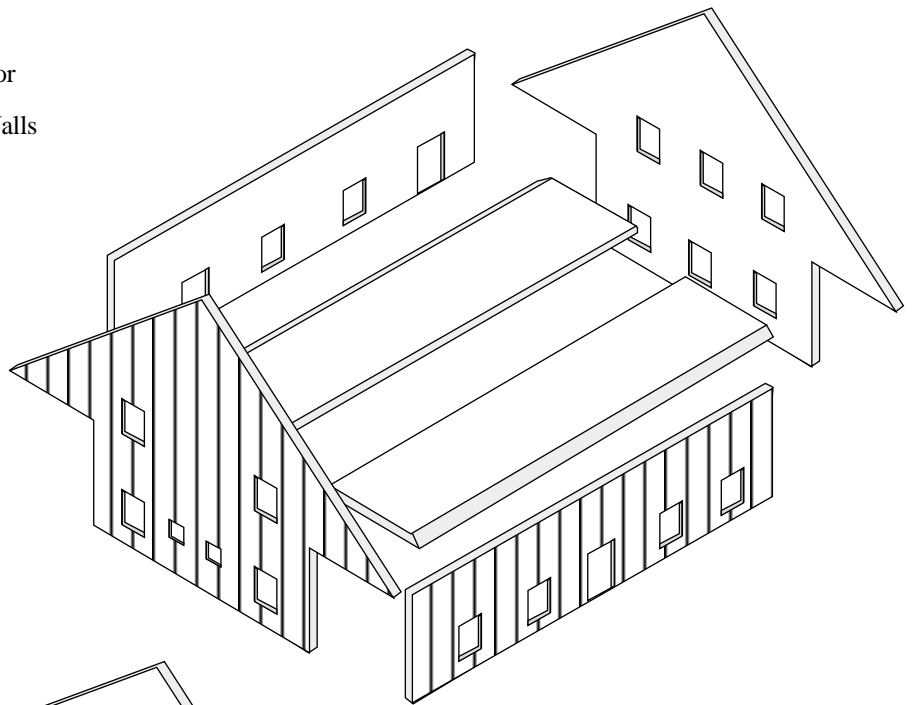

8. Attach walls to frame
Begin with end wall and
continue
with adjacent wall. Glue and
nail the walls in place, always
nailing into the frame, both
top and bottom.

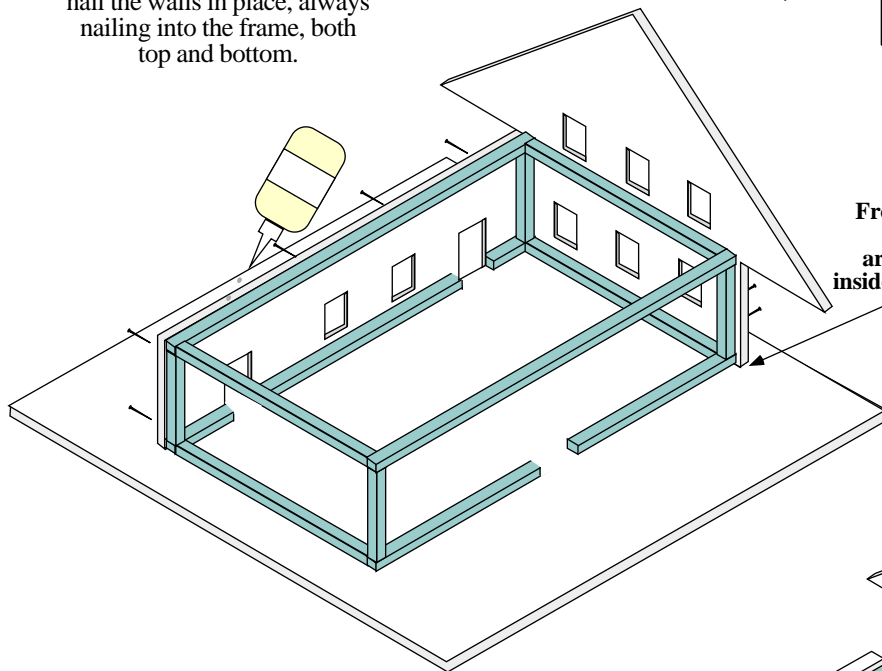

Note:
Front and back
walls
are assembled
inside the end walls.

9. Continue in the same direction
until all walls are in place. Check
that each wall is sturdily attached
and that there are no "floppy" walls.

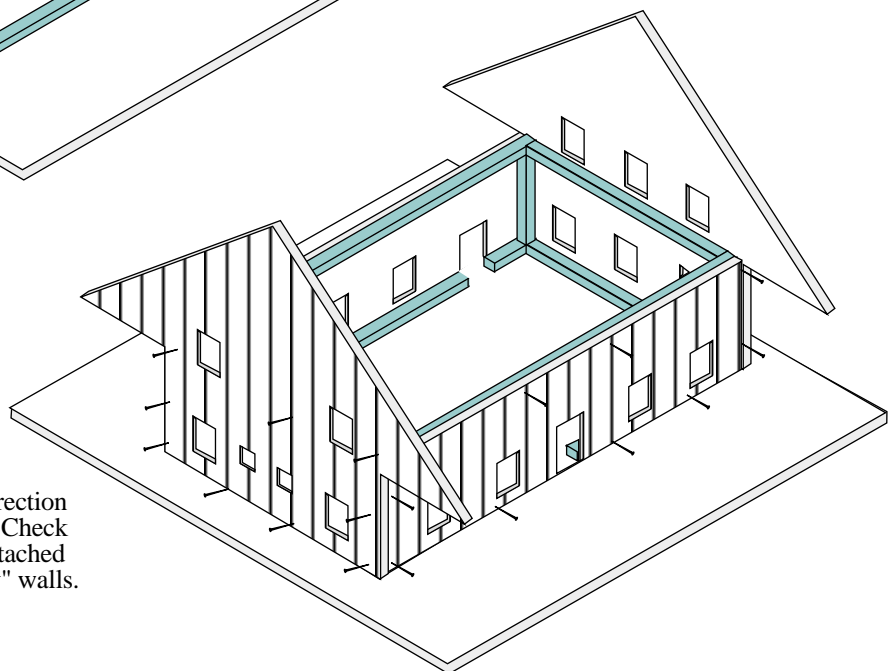

10. We suggest painting your walls prior to installing the doors and windows. "Dings" can be patched up later.

See Assembly - The Walls (page 16)
You can now install your doors
and windows.

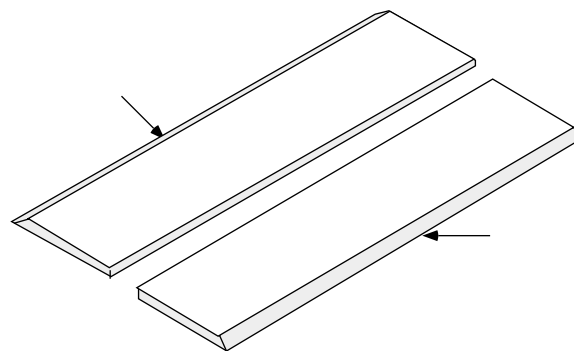
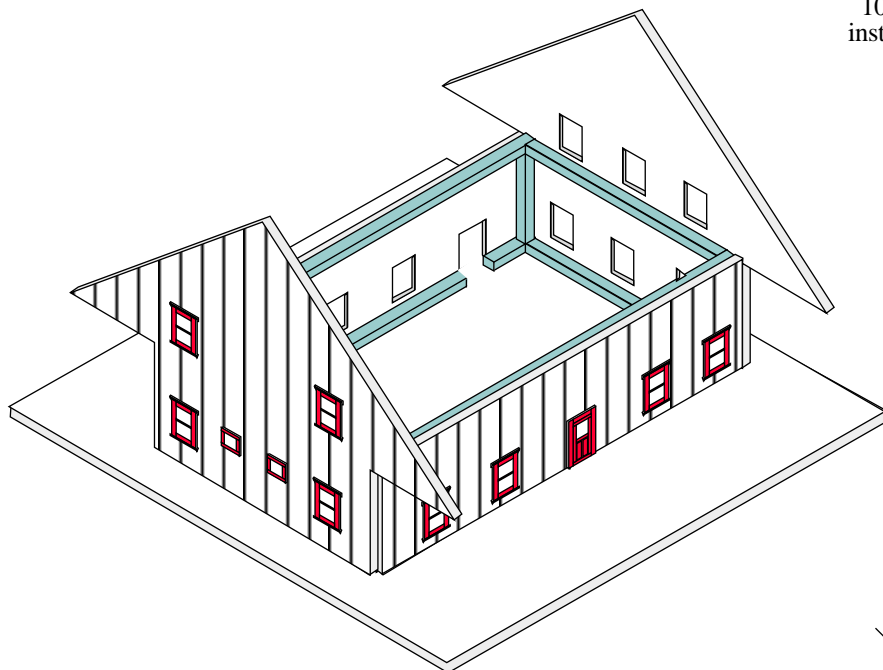

Note: the porch overhang ceiling (parts D) have both been mitered on the top outside edges in order to fit under the roof.

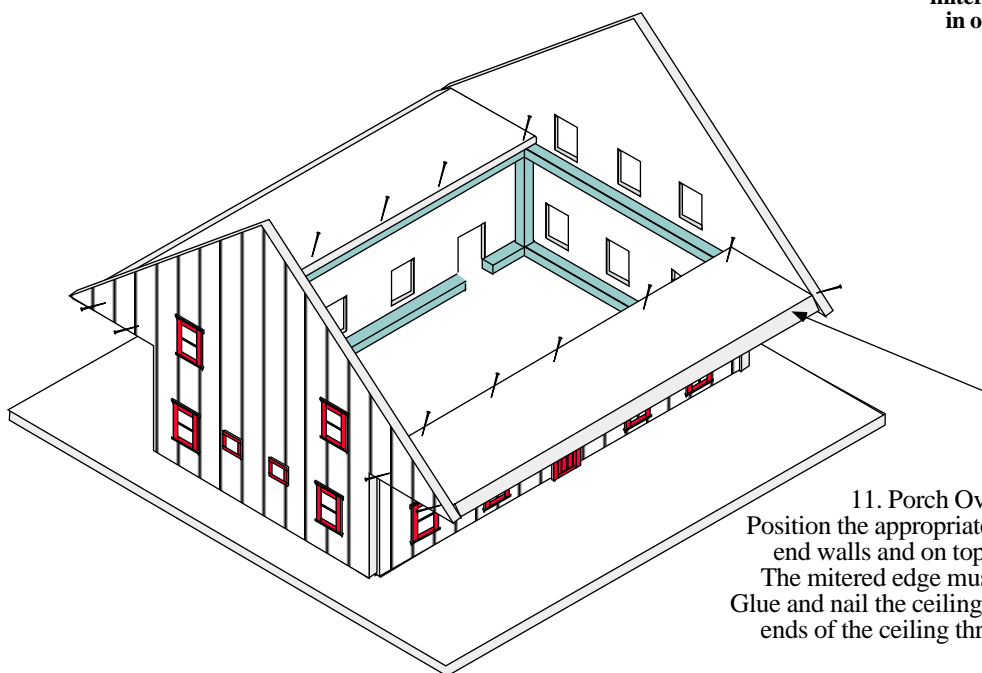

11. Porch Overhang Ceiling
Position the appropriate ceiling between the two end walls and on top of the building frame. The mitered edge must fit under the roof line. Glue and nail the ceiling into the frame. Secure the ends of the ceiling through the two end walls.

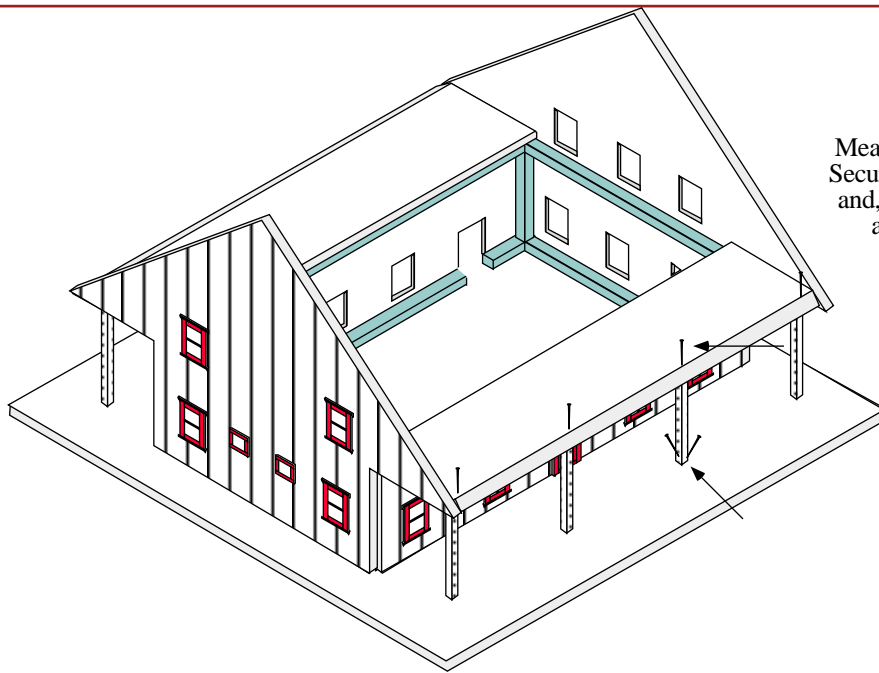

12. Install Porch Posts
Measure and place porch posts.
Secure through the porch ceiling
and, keeping the posts vertical,
attach to the foundation.

**Note: If you are adding lights to
your building, use screws to attach
the roof. This will enable you to
have
access to the wiring.**



13. Attach the roof
Run a bead of glue along the inside tops of the
roof halves where they are mitered and will fit together.
(If you haven't mitered the halves, see Method 2 on page 7)
Also run a bead of glue around the exposed
end wall tops where the roof will be attached.
There will be an overhang on each end,
as well as the porch.
Carefully center and position one roof half in place.
Nail along the top of the End wall.

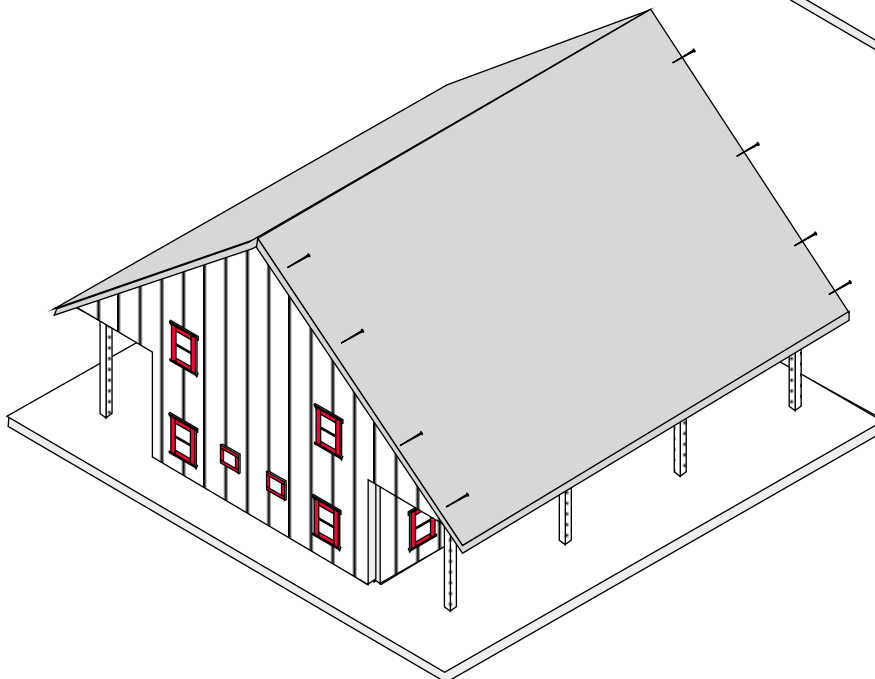
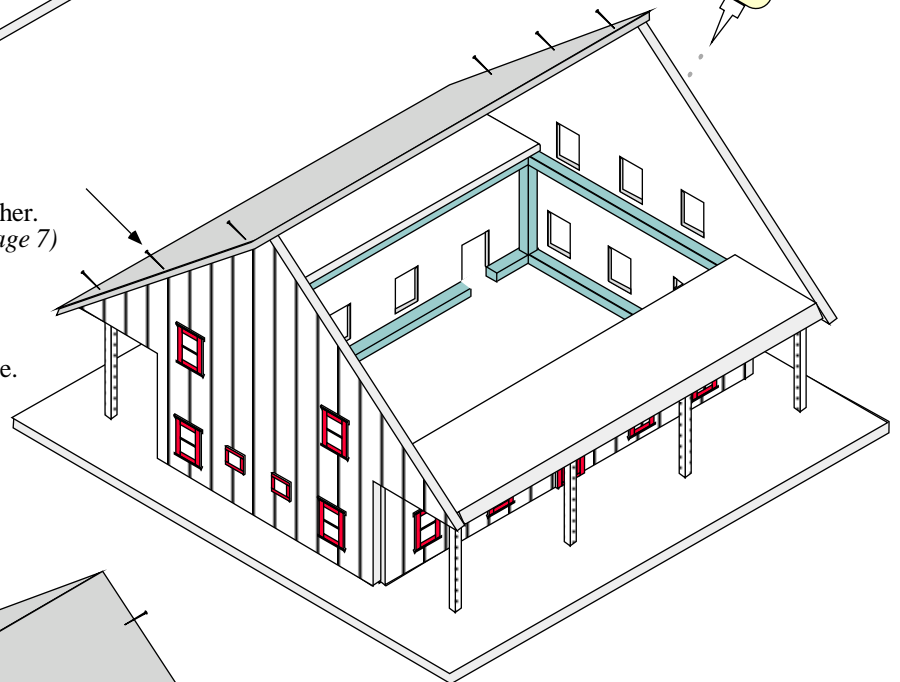

14. Place the second half of the
roof, carefully joining at the top
with the first half. Make sure there
is enough glue along the mitered edges
for the two halves to adhere to each other.
Nail in place.

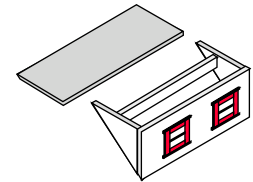
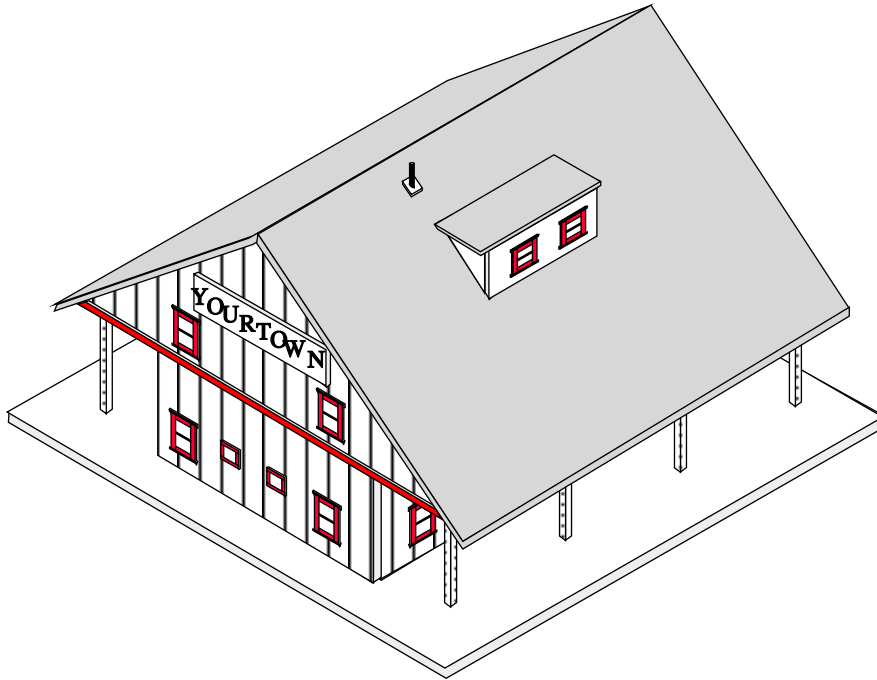

15. Attach the Dormer to the Back of the Railway Station, using instructions with Dormer. Center the Dormer on the roof 6-1/2" down from the top peak.

Signs

Add a large town sign to each end and a small sign to the back wall of the building. (so the passengers know where they are when they disembark)



We suggest using the stick on letters found in arts and craft stores.

1. Paint sign
2. Add letters
3. Seal sign with varnish or equivalent
4. Glue and nail in place.

Add a rooftop pipe



1. Miter the 2" Dowel at 45° angle on bottom.



2. Lay base on a flat surface and glue the dowel to center. Paint the assembly before installing on roof.

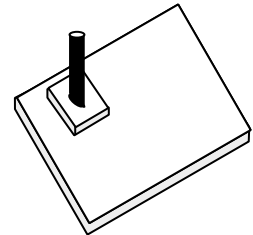

3. When the assembly is attached to the roof, the dowel should be straight up. Attach base to roof with .glue.

Add Trim to Ends

Miter both ends of the trim board at 45° as shown



Trim will fit in alignment with the roof. Paint trim and glue in place when dry.

